



*Blue Book*

# **Swiss Commercial Registry Data Structure**

*XML Data Model*

Version: 1.0

Edition: March 2010

## Table of Contents

<b>PART I INTRODUCTION .....</b>	<b>5</b>
ABOUT THE SWISS COMMERCIAL REGISTRY DATA STRUCTURE DOCUMENTATION .....	6
<b>PART II MODELLING CONCEPTS .....</b>	<b>7</b>
1. XML SCHEMA ROOT .....	8
<b>PART III XML REFERENCE MANUAL .....</b>	<b>11</b>
excerpt.....	12
excerpt/envelope .....	12
excerpt/envelope/schemaVersion .....	13
excerpt/envelope/officeID .....	13
excerpt/envelope/officeName .....	14
excerpt/envelope/creationDate .....	14
excerpt/envelope/validityDate .....	14
excerpt/instances .....	14
excerpt/instances/instance .....	15
<i>addressType</i> .....	16
addressType/addressText .....	16
addressType/addressDetails .....	17
<i>capitalType</i> .....	18
capitalType/capitalAmount .....	19
capitalType/cashedIn.....	19
capitalType/division .....	19
capitalType/division/divisionText .....	20
capitalType/division/details .....	21
capitalType/division/details/detailText .....	22
capitalType/division/details/quantity .....	22
capitalType/division/details/shareCode .....	22
capitalType/division/details/shareText .....	23
capitalType/division/details/valueOfShare .....	23
capitalType/division/details/votingRights .....	23
capitalType/division/details/privileges .....	23
capitalType/allocation .....	24
<i>companyRefType</i> .....	25
companyRefType/CHNum.....	26
companyRefType/IdCantonal .....	26
companyRefType/UID .....	26
companyRefType/other .....	27
companyRefType/link .....	27
<i>diaryType</i> .....	28
diaryType/text .....	28
diaryType/entryNr .....	28
diaryType/date.....	29
diaryType/year.....	29
<i>instanceType</i> .....	30
instanceType/heading .....	31
instanceType/heading/identification .....	32
instanceType/heading/canton.....	32
instanceType/heading/entityStatus.....	32
instanceType/heading/legalForm .....	33
instanceType/heading/legalFormText.....	33
instanceType/heading/inscriptionDate.....	33
instanceType/heading/beginDate .....	33
instanceType/heading/deletionDate .....	34
instanceType/heading/duration .....	34
instanceType/heading/duration/description .....	34
instanceType/heading/duration/termination .....	35
instanceType/heading/transferFrom .....	35
instanceType/heading/transferTo .....	36
instanceType/heading/lastRef .....	36
instanceType/heading/formerIDs.....	37

instanceType/heading/formerIDs/formerID .....	37
instanceType/heading/timestamp .....	38
instanceType/citations .....	38
instanceType/citations/citation .....	39
instanceType/citations/citation/canton .....	39
instanceType/citations/citation/officeID .....	39
instanceType/citations/citation/diary .....	40
instanceType/citations/citation/SHAB .....	41
instanceType/citations/citation/mutFlags .....	41
instanceType/citations/citation/visum .....	42
instanceType/rubrics .....	42
instanceType/rubrics/seats .....	42
instanceType/rubrics/seats/seat .....	43
instanceType/rubrics/seats/seat/seatText .....	43
instanceType/rubrics/seats/seat/bfsNum .....	43
instanceType/rubrics/seats/seat/canton .....	44
instanceType/rubrics/seats/seat/country .....	44
instanceType/rubrics/seats/seat/bfs .....	44
instanceType/rubrics/names .....	44
instanceType/rubrics/names/name .....	45
instanceType/rubrics/names/name/native .....	45
instanceType/rubrics/names/name/translation .....	45
instanceType/rubrics/names/name/notice .....	46
instanceType/rubrics/addresses .....	46
instanceType/rubrics/addresses/address .....	47
instanceType/rubrics/purposes .....	47
instanceType/rubrics/purposes/purpose .....	48
instanceType/rubrics/topics .....	48
instanceType/rubrics/topics/topic .....	49
instanceType/rubrics/capital .....	51
instanceType/rubrics/capital/capitalItem .....	51
instanceType/rubrics/bylaws .....	52
instanceType/rubrics/bylaws/bylaw .....	52
instanceType/rubrics/bylaws/bylaw/date .....	52
instanceType/rubrics/bylaws/bylaw/text .....	53
instanceType/rubrics/branches .....	53
instanceType/rubrics/branches/branch .....	54
instanceType/rubrics/branches/branch/identification .....	55
instanceType/rubrics/branches/branch/fullText .....	55
instanceType/rubrics/branches/branch/bfsNum .....	55
instanceType/rubrics/branches/branch/seatText .....	56
instanceType/rubrics/HQinfos/HQinfo .....	56
instanceType/rubrics/HQinfos/HQinfo/HQid .....	56
instanceType/rubrics/HQinfos/HQinfo/HQtext .....	57
instanceType/rubrics/persons .....	58
instanceType/rubrics/persons/person .....	58
<i>locationType</i> .....	59
locationType/destination .....	59
locationType/co .....	60
locationType/attention .....	60
locationType/street .....	60
locationType/buildingNum .....	60
locationType/streetAddOn .....	61
locationType/poBoxNum .....	61
locationType/zip .....	61
locationType/city .....	61
locationType/country .....	62
locationType/bfsNum .....	62
locationType/cantonalLocNum .....	62
locationType/federalLocNum .....	62
<i>personType</i> .....	63
personType/refCancel .....	64
personType/particulars .....	64
personType/particulars/identification .....	65
personType/particulars/PID .....	65
personType/particulars/name .....	65
personType/particulars/mrMrs .....	66
personType/particulars/title .....	66

personType/particulars/firstName.....	66
personType/particulars/origins.....	66
personType/particulars/origins/origin.....	67
personType/particulars/origins/origin/city.....	67
personType/particulars/origins/origin/bfsNum.....	68
personType/particulars/origins/origin/country.....	68
personType/particulars/origins/origin/phrase.....	68
personType/particulars/origins/origin/adjective.....	68
personType/particulars/residence.....	69
personType/particulars/residence/city.....	69
personType/particulars/residence/zip.....	69
personType/particulars/residence/bfsNum.....	69
personType/particulars/residence/country.....	70
personType/particulars/yearOfBirth.....	70
personType/particulars/personText.....	70
personType/functions.....	70
personType/functions/function.....	71
personType/functions/function/funcCode.....	71
personType/functions/function/funcText.....	74
personType/functions/function/authorisation.....	74
personType/functions/function/authorisation/authCode.....	74
personType/functions/function/authorisation/authText.....	76
personType/functions/function/authorisation/extraCode.....	76
personType/functions/function/authorisation/extraText.....	77
personType/functions/function/authorisation/signShort.....	77
personType/functions/function/authorisation/extraShort.....	77
personType/functions/function/funcShort.....	78
personType/warranties.....	78
personType/warranties/warranty.....	79
personType/warranties/warranty/warrantyCode.....	79
personType/warranties/warranty/warrantyText.....	80
personType/warranties/warranty/amount.....	80
personType/warranties/warranty/quantity.....	80
personType/warranties/warranty/value.....	80
personType/warranties/warranty/currency.....	81
personType/warranties/warranty/votingRights.....	81
personType/warranties/warranty/privileges.....	81
<b>SHABType.....</b>	<b>82</b>
SHABType/text.....	82
SHABType/shabNum.....	82
SHABType/page.....	83
SHABType/pubNum.....	83
SHABType/date.....	83
SHABType/year.....	83
<b>bfsNumType.....</b>	<b>84</b>
<b>cantonType.....</b>	<b>85</b>
<b>CHNumType.....</b>	<b>86</b>
<b>countryType.....</b>	<b>87</b>
<b>currencyType.....</b>	<b>88</b>
<b>langType.....</b>	<b>89</b>
<b>legalFormType.....</b>	<b>90</b>
<b>UIDtype.....</b>	<b>91</b>
<b>citeGroup (Attribute Group).....</b>	<b>92</b>
<b>hr:companyRefType.....</b>	<b>93</b>
<b>hr:CHNumType.....</b>	<b>93</b>
<b>hr:UIDType.....</b>	<b>93</b>
<b>hr:attnGroup (Attribute Group).....</b>	<b>94</b>
<b>PART IV GLOSSARY (ENGLISH – GERMAN – FRENCH).....</b>	<b>94</b>

# Part I

## *Introduction*

## About The Swiss Commercial Registry Data Structure Documentation

The *Swiss Commercial Registry Data Structure* is an eXtended Markup Language (XML) Data Model, which specifies the data structure that will enable the exchange of commercial registry information of legal entities between different Cantonal Commercial Registries. These data consist of the

- (i) data for the excerpt of a registered legal entity, which includes all the data that has to be published according to the Swiss Federal Ordinance of the Registry of Commerce; and
- (ii) data of a registered legal entity, which is marked with the so-called “hr”-namespace, because this is used by the Cantonal Commercial Registries for internal administrative purposes.

This document serves primarily the technical experts, data base programmers and software architects of the Cantonal Commercial Registries as a reference book for integrating the electronic registry information into their legal entity information system.

This document is structured as follows:

Part I: Part I is a brief introduction of the purpose of the *Swiss Commercial Registry Data Structure*.

Part II: This part explains the underlying modelling concepts of the *Swiss Commercial Registry Data Structure*.

Part III: The third part is the so-called ‘XML Reference Manual’, which specifies in detail the data types and elements used in the XML Data Model.

Part IV: The last part is a cross-language glossary (English – German – French) of the most used terms in the *Swiss Commercial Registry Data Structure*.

Furthermore, please note that the *Swiss Commercial Registry Data Structure* documentation is published on the internet: <http://www.zefix.ch/standards>

# **Part II**

## ***Modelling Concepts***

## 1. XML Schema Root

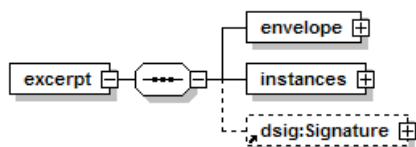

With each XML file you get one XML data set of a legal entity. At the root of such XML data sets, there is the so-called 'excerpt' node, which refers to following three XML sub-trees:

- (i) Subtree 'envelope': The subtree 'envelope' is a container of metadata, which specifies such information as the issuing Cantonal Commercial Registry, the excerpt's language, its validity and whether the excerpt contains only up-to-date information or consist of all information (i.e. up-to-date information as well as information resulting of past activities [e.g. deletions]; see below "Subtree 'envelope'").
- (ii) Subtree 'instances': The subtree 'instances' is based on the 'instance type', which is the root of another distinct XML sub-tree that contains the various excerpt data (see below "Subtree 'instances'"). Please note that 'instances' are necessary in order to deal with the former use of so-called file-cards by the Cantonal Commercial Registries at the time when no computers were used for registering legal entities. Therefore, the first 'instance' represents the latest in history and thus contains the latest available information about a legal entity. However, other instance structures may be of interest for doing research about the information resulting of past activities of a legal entity.
- (iii) Subtree 'signature': The subtree 'signature' contains the Cantonal Commercial Registry's digital signature that serves as a proof of integrity and origin of the XML data set (see below "Subtree 'signature'"). Technically, it is an embedded, enveloped XML signature. Please note, that the subtree 'signature' is only optional.

## 2. Subtree 'envelope'

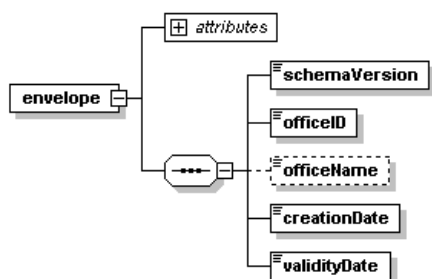

At the root of the 'envelope', the node refers to following components:

- (iv) 'schemaVersion': The 'schemaVersion' refers to the version of the XML schema.
- (v) 'officeID': The 'officeID' refers to the identification number of the Cantonal Commercial Registry which is publishing the excerpt.
- (vi) 'officeName': The 'officeName' refers to the name of the Cantonal Commercial Registry which is publishing the excerpt (optional).
- (vii) 'creationDate': The 'creationDate' refers to the date on which the Cantonal Commercial Registry created the excerpt.



- (viii) 'validityDate': The *'validityDate'* refers to the date on which the Cantonal Commercial Registry validated the excerpt.

### 3. Subtree 'instances'

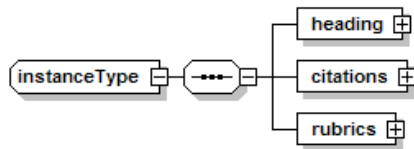

The *'instanceType'* refers to the *'instances'*. At the root of the *'instanceType'*, the node refers to following three components:

- (ix) 'Heading': The *'heading'* contains the key information about the legal entity like the legal entity's identification number, legal form, inscription date etc.
- (x) 'Citations': The *'citations'* are referential information to each fact reported in the excerpt (e.g. diary reference, SOGC [Swiss Official Gazette of Commerce] reference etc.).
- (xi) 'Rubrics': The *'rubrics'* encompass all the data that have to be published in the Commercial Registry (e.g. like the data which have to be published according to the Swiss Federal Ordinance of the Registry of Commerce).

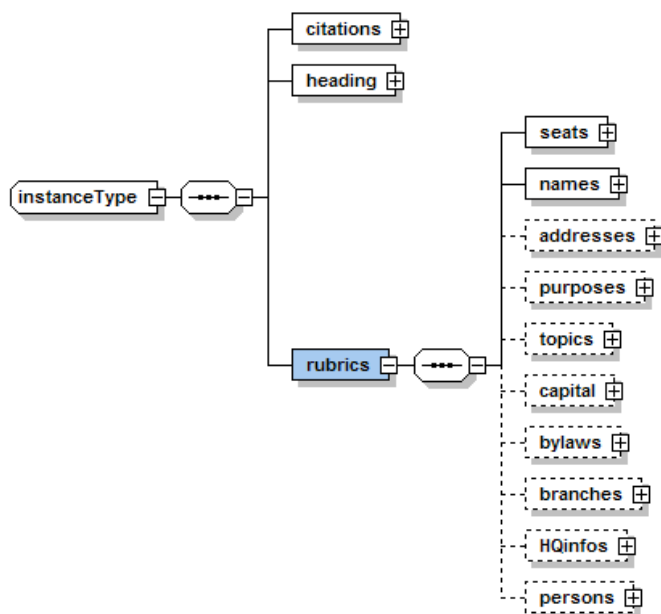

The *'rubrics'* consists of the following data elements:

- (xii) 'Seats': Domicile of a legal entity (i.e. present domicile as well as former domiciles of the legal entity).
- (xiii) 'Names': Names of a legal entity (i.e. present name, translations of the name as well as former names of the legal entity).

- (xiv) 'Addresses': Addresses of a legal entity (i.e. present address, additional addresses as well as former addresses of the legal entity).
- (xv) 'Purposes': Purpose of a legal entity (i.e. present purpose as well as former purposes of the legal entity)
- (xvi) 'Topics': Data which is not suitable for structured storage. Such information is specified by the attribute, topicCode.
- (xvii) 'Capital': Capitalisation of the legal entity.
- (xviii) 'Bylaws': Information regarding the articles of incorporation/bylaws (e.g. date of the last change of the articles of incorporation/bylaws).
- (xix) 'Branches': Identification number and address of branch offices.
- (xx) 'HQinfos': Information regarding the head office of a branch (e.g. domicile).
- (xxi) 'Persons': Data related to persons (e.g. family name, first name, place of birth, nationality, domicile, functions) or legal entities (e.g. name of a legal entity, identification number).

#### 4. Subtree 'signature'

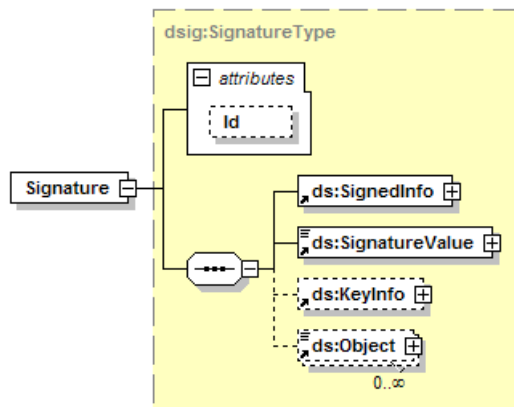

The subtree 'signature' contains the Cantonal Commercial Registry's digital signature that serves as a proof of integrity and origin of the XML data set. Technically, it is an embedded, enveloped XML signature. The schema definition of Signature is taken from the standard for XML signatures issued by the W3C on digital XML signatures. As aforementioned, please note that the subtree 'signature' is only optional.

# **Part III**

## ***XML Reference Manual***

excerpt	
<b>Model</b>	
<b>Appearance</b>	
/ (root)	
<b>Data Type</b>	<b>Occurrence</b>
-	min = 1 / max = 1
<b>Semantics / Business Rules</b>	
Root element.	

excerpt/envelope	
<b>Model</b>	
<b>Data Type</b>	<b>Occurrence</b>
-	min = 1 / max = 1
<b>Attributes</b>	
lang	langType (required) → Language in which the excerpt is delivered.
lastInstanceOnly	xs:int (restricted, optional) → 1 = The excerpt is based on the last file card.
activeOnly	xs:int (restricted, optional) → 1 = The excerpt reports only valid facts, not deleted ones.
<b>Semantics / Business Rules</b>	
<p>The lang attribute specifies the language, in which the excerpt is being depicted / printed. Note that the main content may be expressed in a different language. The lang attribute mainly applies to the titles, labels and explanatory remarks used in the excerpt.</p> <p>See the lang attribute in instanceType/heading regarding the language of the excerpt's content.</p>	

<b>excerpt/envelope/schemaVersion</b>	
<b>Data Type</b> xs:token	<b>Occurrence</b> min = 1 / max = 1
<b>Restrictions</b> -	<b>Example Usage</b> <schemaVersion>1.0</schemaVersion>
<b>Semantics / Business Rules</b> Version of the schema.	

<b>excerpt/envelope/officeID</b>	
<b>Data Type</b> xs:int	<b>Occurrence</b> min = 1 / max = 1
<b>Restrictions</b> Table of the Cantonal Commercial Registries and their identifiers as mentioned below.	<b>Example Usage</b> <officeID>36</officeID>
<b>Semantics / Business Rules</b> Cantonal Commercial Registry which has made the excerpt.	

officeID	Office
20	ZH
36	BE
100	LU
120	UR
130	SZ
140	OW
150	NW
160	GL
170	ZG
217	FR
241	SO
270	BS
280	BL
290	SH
300	AR

officeID	Office
310	AI
320	SG
350	GR
400	AG
440	TG
501	TI
550	VD
600	VS (Oberwallis)
601	<i>reserved</i>
621	VS (Unterwallis)
626	VS (Zentralwallis)
645	NE
660	GE
670	JU

excerpt/envelope/officeName	
<b>Data Type</b> xs:token	<b>Occurrence</b> min = 0 / max = 1
<b>Restrictions</b> -	<b>Example Usage</b> <officeName> <b>Handelsregisteramt des Kantons Bern</b> </officeName>
<b>Semantics / Business Rules</b> Official name of the Cantonal Commercial Registry.	

excerpt/envelope/creationDate	
<b>Data Type</b> xs:dateTime	<b>Occurrence</b> min = 1 / max = 1
<b>Restrictions</b> -	<b>Example Usage</b> <creationDate>2009-05-28T10:18:23 </creationDate>
<b>Semantics / Business Rules</b> Particular time when the excerpt was made / created by the Cantonal Commercial Registry.	

excerpt/envelope/validityDate	
<b>Data Type</b> xs:date	<b>Occurrence</b> min = 1 / max = 1
<b>Restrictions</b> -	<b>Example Usage</b> <validityDate>2002-05-02 </validityDate>
<b>Semantics / Business Rules</b> Date of the last official publication (in the SOGC [Swiss Official Gazette of Commerce]) to which the excerpt refers.	

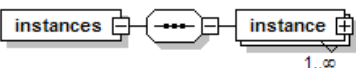
excerpt/instances	
<b>Model</b>  <pre> classDiagram     class instances     class instance     instances "1" -- "1..∞" instance           </pre>	
<b>Data Type</b> -	<b>Occurrence</b> min = 1 / max = 1
<b>Semantics / Business Rules</b> Contains the various instances of the excerpt (at least one).	

**excerpt/instances/instance**

**Model**

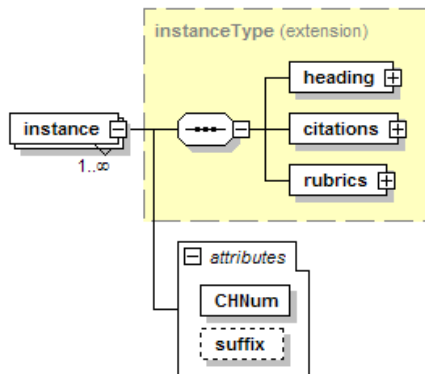

**Data Type**

instanceType

**Occurrence**

min = 0 / max = unbounded

**Attributes**

CHNum

CHNumType (required) → The legal entity's official identification number

suffix

xs:token (optional) → Addendum to CHNum, used to distinguish different instances from each other, e.g. "b" or "\_".

**Semantics / Business Rules**

'Instance' is the root of another distinct XML sub-tree that contains the various excerpt data. Please note that 'instances' are necessary in order to deal with the former use of so-called file-cards by the Cantonal Commercial Registries at the time when no computers were used for registering legal entities. Therefore, the first 'instance' represents the latest in history and thus contains the latest available information about a legal entity. However, other instance structures may be of interest for doing research about the information resulting of past activities of a legal entity.

In the presence of more than one `instance` element, each element is uniquely identified by `CHNum` and `suffix`, two attributes assigned to the instance element. In order to find the most recent instance – the one with the latest information in it – it is necessary to check for the `instance` element that has no value in `heading/transferTo`.

**addressType**

**Model**

**Appearance**  
 excerpt / instance / rubrics / addresses / address

**Attributes**

citeGroup	see definition on page 92
lang	langType (optional) → Language in which the address information is stored.
kind	xs:token (restricted, optional) → A classification of the address, distinguished by purpose, like the address of the domicile, the postal address, the address of the legal entity's place of administration, or any other.
	enumeration seat
	enumeration postal
	enumeration admin
	enumeration other

**Remarks**  
 -

addressType / addressText	
<b>Data Type</b> xs:string	<b>Occurrence</b> min = 1 / max = 1
<b>Restrictions</b> -	<b>Example Usage</b> <addressText> <b>Bundesrain 20, 3003 Bern</b> </addressText>
<b>Semantics / Business Rules</b> String suitable for printing the address on a letter.	



addressType/addressDetails	
<p><b>Model</b></p> <pre> classDiagram     class addressDetails {         locationType     }     class locationType {         destination         co         attention         street         buildingNum         streetAddOn         poBoxNum         zip         city         country         bfsNum         cantonalLocNum         federalLocNum     }     addressDetails --&gt; locationType             </pre>	
<p><b>Data Type</b> locationType</p>	<p><b>Occurrence</b> min = 0 / max = 1</p>
<p><b>Attributes</b> -</p>	
<p><b>Semantics / Business Rules</b> Structured address information.</p>	

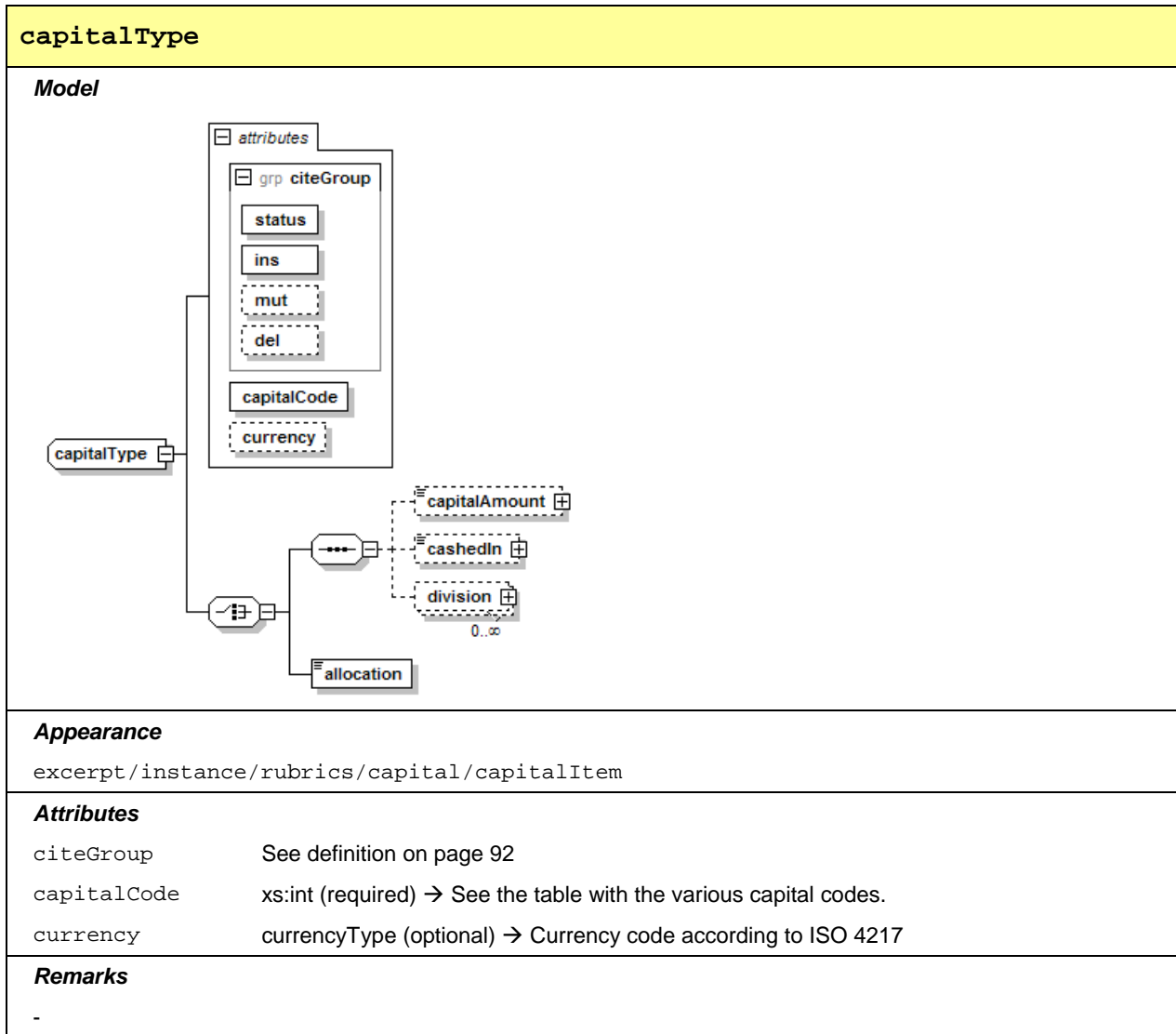

capitalCode	De	Fr	It
1	Stammkapital	capital social	Capitale sociale
2	Aktienkapital	capital actions	Capitale azionario
3	Partizipationskapital	capital participation	Capitale di partecipazione
4	Gesamtkommanditsumme	montant total des commandites	Capitale accomandato complessivo
9	Variables Kapital	capital variable	Capitale variabile

capitalType/capitalAmount	
<b>Data Type</b> xs:decimal (extended)	<b>Occurrence</b> min = 0 / max = 1
<b>Attributes</b> status                    xs:int (required) → 1 = This is the current record 0 = This is an old record (a previously deleted record)	
<b>Restrictions</b> -	<b>Example Usage</b> <capitalAmount>250000</capitalAmount>
<b>Semantics / Business Rules</b> Total amount of the legal entity's capital (e.g. share capital, quota capital, cooperative capital etc.).	

capitalType/cashedIn	
<b>Data Type</b> xs:decimal (extended)	<b>Occurrence</b> min = 0 / max = 1
<b>Attributes</b> status                    xs:int (restricted, required) → 1 = This is the current record 0 = This is an old record (a previously deleted record)  del                        xs:int (optional) → If the amount of the contributed money has changed, this data shows the citation reference in the so-called "cash" column that has been deleted. Most of the time this data is the same as in citeGroup.del	
<b>Restrictions</b> -	<b>Example Usage</b> <cashedIn>250000</cashedIn>
<b>Semantics / Business Rules</b> Amount of the money contributions that have been paid in.	

capitalType/division	
<b>Model</b>	
<b>Data Type</b> -	<b>Occurrence</b> min = 0 / max = unbounded
<b>Semantics / Business Rules</b> Capital of the legal entity split into shares, quotas, cooperative shares etc.	

<b>capitalType/division/divisionText</b>	
<b>Data Type</b> xs:token (extended)	<b>Occurrence</b> min = 1 / max = 1
<b>Attributes</b>	
status	xs:int (restricted) → 1 = This is the current record 0 = This is an old record (a previously deleted record)
del	xs:int (optional) → If the division of the shares, quotas, cooperative shares etc. has changed, this data shows the citation reference in the so-called "division" column that has been deleted. Most of the time this data is the same as in citeGroup.del
<b>Restrictions</b> -	<b>Example Usage</b> <divisionText> 25'000 Namenaktien zu CHF 10.-- </divisionText>
<b>Semantics / Business Rules</b> Division in shares, quotas, cooperative shares etc. as published in the excerpt.	

capitalType/division/details							
<p><b>Model</b></p> <pre> classDiagram     class details     class attributes {         status         del         restrictions     }     class detailText     class quantity     class shareCode     class shareText     class valueOfShare     class votingRights     class privileges      details -- attributes     details -- detailText     details -- quantity     details -- shareCode     details -- shareText     details -- valueOfShare     details -- votingRights     details -- privileges     </pre>							
<p><b>Data Type</b></p> <p>-</p>	<p><b>Occurrence</b></p> <p>min = 1 / max = 1</p>						
<p><b>Attributes</b></p> <table border="0"> <tr> <td style="vertical-align: top;">status</td> <td>xs:int (restricted, required) → 1 = This is the current record 0 = This is an old record (a previously deleted record)</td> </tr> <tr> <td style="vertical-align: top;">del</td> <td>xs:int (optional) → If the division in shares, quotas, cooperative shares etc. has changed, this data indicates the citation reference in the so-called "division" column that has been deleted. Most of the time this data is the same as citeGroup.del</td> </tr> <tr> <td style="vertical-align: top;">restrictions</td> <td>xs:int (restricted, optional) → 1 = Transferability of registered shares or quotas is restricted ("Vinkulierung") 0 = Registered shares or quotas may be transferred without restrictions.</td> </tr> </table>		status	xs:int (restricted, required) → 1 = This is the current record 0 = This is an old record (a previously deleted record)	del	xs:int (optional) → If the division in shares, quotas, cooperative shares etc. has changed, this data indicates the citation reference in the so-called "division" column that has been deleted. Most of the time this data is the same as citeGroup.del	restrictions	xs:int (restricted, optional) → 1 = Transferability of registered shares or quotas is restricted ("Vinkulierung") 0 = Registered shares or quotas may be transferred without restrictions.
status	xs:int (restricted, required) → 1 = This is the current record 0 = This is an old record (a previously deleted record)						
del	xs:int (optional) → If the division in shares, quotas, cooperative shares etc. has changed, this data indicates the citation reference in the so-called "division" column that has been deleted. Most of the time this data is the same as citeGroup.del						
restrictions	xs:int (restricted, optional) → 1 = Transferability of registered shares or quotas is restricted ("Vinkulierung") 0 = Registered shares or quotas may be transferred without restrictions.						
<p><b>Semantics / Business Rules</b></p> <p>Structured information about the division in shares, quotas, cooperative shares etc. A separate details element is used for each division in shares, quotas, cooperative shares etc.</p>							

<b>capitalType/division/details/detailText</b>	
<b>Data Type</b> xs:token	<b>Occurrence</b> min = 0 / max = 1
<b>Restrictions</b> -	<b>Example Usage</b> <detailText> 25'000 Namenaktien zu CHF 10.-- </detailText>
<b>Semantics / Business Rules</b> Division in shares, quotas, cooperative shares etc. as published in the excerpt.	

<b>capitalType/division/details/quantity</b>	
<b>Data Type</b> xs:int	<b>Occurrence</b> min = 0 / max = 1
<b>Restrictions</b> -	<b>Example Usage</b> <quantity>25000</quantity>
<b>Semantics / Business Rules</b> The number of shares, quotas, cooperative shares etc.	

<b>capitalType/division/details/shareCode</b>	
<b>Data Type</b> xs:int	<b>Occurrence</b> min = 0 / max = 1
<b>Restrictions</b> minInclude = 1 / maxInclude = 4	<b>Example Usage</b> <shareCode>1</shareCode>
<b>Semantics / Business Rules</b> Table of shareCodes below.	

shareCode	De	Fr	It
1	Inhaberaktie	actions au porteur	Azioni al portatore
2	Namenaktie	actions nominatives	Azioni nominative
3	Inhaberpartizipationsschein	bons de participation au porteur	Buoni di partecipazione al portatore
4	Namenspartizipationsschein	bons de participation nominatifs	Buoni di partecipazione nominativi

<b>capitalType/division/details/shareText</b>	
<b>Data Type</b> xs:token	<b>Occurrence</b> min = 0 / max = 1
<b>Restrictions</b> -	<b>Example Usage</b> <shareText>Namenaktie</shareText>
<b>Semantics / Business Rules</b> Type of shares according to shareCode.	

<b>capitalType/division/details/valueOfShare</b>	
<b>Data Type</b> xs:decimal	<b>Occurrence</b> min = 0 / max = 1
<b>Restrictions</b> -	<b>Example Usage</b> <valueOfShare>10</valueOfShare>
<b>Semantics / Business Rules</b> Par value of the shares, quotas, cooperative shares etc.	

<b>capitalType/division/details/votingRights</b>	
<b>Data Type</b> xs:token	<b>Occurrence</b> min = 0 / max = 1
<b>Restrictions</b> -	<b>Example Usage</b> <votingRights> Stimmrechtsaktien </votingRights>
<b>Semantics / Business Rules</b> Textual description of the voting rights linked to shares with privileged voting rights.	

<b>capitalType/division/details/privileges</b>	
<b>Data Type</b> xs:token	<b>Occurrence</b> min = 0 / max = 1
<b>Restrictions</b> -	<b>Example Usage</b> <privileges>Vorzugsaktien</privileges>
<b>Semantics / Business Rules</b> Textual description of the privileges linked to preferred shares.	

<b>capitalType/allocation</b>	
<b>Data Type</b> xs:token	<b>Occurrence</b> min = 1 / max = 1
<b>Restrictions</b> -	<b>Example Usage</b> <allocation>Die Genossenschaft verkauft <b>Anteilscheine</b> </allocation>
<b>Semantics / Business Rules</b> If the legal entity is a cooperative ("Genossenschaft"), then the only information about the capital structure is a text.	



<b>companyRefType</b>	
<b>Model</b>	
<pre> classDiagram     class companyRefType {         attributes {             officeID             date         }         CHNum         IdCantonal         UID         other         link     }         </pre>	
<b>Appearance</b>	
<p>excerpt/instance/heading/identification                  excerpt/instance/heading/transferFrom                  excerpt/instance/heading/transferTo                  excerpt/instance/rubrics/HQinfos/HQinfo/HQid                  excerpt/instance/rubrics/branches/branch/identification                  personType/particulars/company/identification</p>	
<b>Attributes</b>	
officeID	xs:int (optional) → Identifier of the office responsible for this record
date	xs:date (optional) → Date of entry of this record
<b>Remarks</b>	
<p>Used to reference a legal entity by one or more identification tokens (e.g. the identification number of the commercial registry [CHNum], an identifier used by the office [IdCantonal] or the future legal entity identifier (UID) etc.</p>	

<b>companyRefType / CHNum</b>	
<b>Data Type</b> CHNumType (extended)	<b>Occurrence</b> min = 0 / max = 1
<b>Attributes</b> suffix                      xs:token (optional) → A suffix to CHNum used to distinguish separate instances of itself (see Business Rules). An underline character ("_") indicates that no suffix is required to find the legal entity in the database. Otherwise, the suffix must be provided in order to retrieve various instances.	
<b>Restrictions</b> -	<b>Example Usage</b> <CHNum suffix="b"> <u>CH-270.3.002.355-7</u> </CHNum>
<b>Semantics / Business Rules</b> CHNum is the identification number of the Cantonal Commercial Registry assigned to the legal entity.  Attribute suffix is used in rare cases when a legal entity has transferred its domicile from one Canton to another and subsequently returned to the initial Canton (e.g. a legal entity transferred its domicile from Zurich to Basel and then returned to Zurich). In such a case, the legal entity's old records – those before the transfer – must be distinguishable from the new records. Therefore, the suffix is used to differentiate the old from the new records with the help of the legal entity's identification number.	

<b>companyRefType / IdCantonal</b>	
<b>Data Type</b> xs:token (extended)	<b>Occurrence</b> min = 0 / max = 1
<b>Attributes</b> suffix                      xs:token (optional) → A suffix to IdCantonal used to distinguish separate instances of it.	
<b>Semantics / Business Rules</b> IdCantonal is an identification number issued by the Cantonal Commercial Registry. As it might be the case with CHNum, IdCantonal can become ambiguous if the legal entity transferred its domicile to another Canton and then returned to the initial Canton.	

<b>companyRefType / UID</b>	
<b>Data Type</b> UIDType	<b>Occurrence</b> min = 0 / max = 1
<b>Restrictions</b> -	<b>Example Usage</b> <UID> <u>CHE-999.999.998</u> </UID>
<b>Semantics / Business Rules</b> The legal entity's identification number issued by the future UID registry of the Swiss Federal Statistical Office.	

<b>companyRefType/other</b>	
<b>Data Type</b> xs:string	<b>Occurrence</b> min = 0 / max = 1
<b>Restrictions</b> -	<b>Example Usage</b> <other>4711</other>
<b>Semantics / Business Rules</b> Any other suitable identifier for the legal entity.	

<b>companyRefType/link</b>	
<b>Data Type</b> xs:string	<b>Occurrence</b> min = 0 / max = 1
<b>Restrictions</b> -	<b>Example Usage</b> <link> <a href="http://www.bluebook.ch">http://www.bluebook.ch</a> </link>
<b>Semantics / Business Rules</b> Internet Hyperlink to a website suitable for identifying the legal entity.	

diaryType	
<p><b>Model</b></p>	
<p><b>Appearance</b></p> <p>excerpt/instance/citations/citation/diary</p>	
<p><b>Attributes</b></p> <p>kindOfEntry            xs:token (restricted, optional) →                                    N (normal):        Ordinary entry                                    R (rectification): Entry rectifies a previous one                                    C (complement): Entry complements an existing one                                    P (carryover):    Indicates a carry-over from a previous file card.</p>	
<p><b>Remarks</b></p> <p>Describes the part of the citation that deals with the diary. In most cases, entryNr and date are sufficiently specifying the respective entry in the diary.</p>	

diaryType/text	
<p><b>Data Type</b></p> <p>xs:token</p>	<p><b>Occurrence</b></p> <p>min = 1 / max = 1</p>
<p><b>Restrictions</b></p> <p>-</p>	<p><b>Example Usage</b></p> <p>&lt;text&gt;Auslassung&lt;/text&gt;</p>
<p><b>Semantics / Business Rules</b></p> <p>In some cases the transition from the old-fashioned paper-based records to modern computers left some of the data records with ambiguous content due to lack of information. text can overcome this difficulty by providing information that otherwise would not fit into the scheme. Its use indicates that either entryNr or both date and year could not be provided or there may have been a carry-over.</p>	

diaryType/entryNr	
<p><b>Data Type</b></p> <p>xs:int</p>	<p><b>Occurrence</b></p> <p>min = 1 / max = 1</p>
<p><b>Restrictions</b></p> <p>-</p>	<p><b>Example Usage</b></p> <p>&lt;entryNr&gt;2243&lt;/entryNr&gt;</p>
<p><b>Semantics / Business Rules</b></p> <p>Entry number of the record in the diary.</p>	

<b>diaryType/date</b>	
<b>Data Type</b> xs:date	<b>Occurrence</b> min = 1 / max = 1
<b>Restrictions</b> -	<b>Example Usage</b> <date>1996-04-24</date>
<b>Semantics / Business Rules</b> Date of the entry in the diary.	

<b>diaryType/year</b>	
<b>Data Type</b> xs:gYear	<b>Occurrence</b> min = 1 / max = 1
<b>Restrictions</b> -	<b>Example Usage</b> <year>1996</year>
<b>Semantics / Business Rules</b> year is only provided exceptionally when the exact date is not known. This can happen if very old paper-based records have been used for the setup of the electronic diary.	

<b>instanceType</b>
<p><b>Model</b></p> <pre> classDiagram     class instanceType     class heading     class citations     class rubrics     instanceType "1" -- "*" heading     instanceType "1" -- "*" citations     instanceType "1" -- "*" rubrics     </pre>
<p><b>Appearance</b></p> <p>excerpt/instances/instance</p>
<p><b>Attributes</b></p> <p>-</p>
<p><b>Remarks</b></p> <p><i>InstanceType</i> is the main data structure of the excerpt. See excerpt/instances/instance for an explanation of the concept of <i>instance</i>.</p>

instanceType/heading	
<p><b>Model</b></p>	
<p><b>Data Type</b></p> <p>-</p>	<p><b>Occurrence</b></p> <p>min = 1 / max = 1</p>
<p><b>Attributes</b></p> <p>lang langType (required) → The language of the excerpt's content</p>	
<p><b>Semantics / Business Rules</b></p> <p>The excerpt heading data.</p> <p>The lang attribute specifies the language of the excerpt's content. The language is specified with the lang attribute in excerpt/envelope.</p>	

<b>instanceType/heading/identification</b>	
<p><b>Model</b></p>	
<p><b>Data Type</b> companyRefType</p>	<p><b>Occurrence</b> min = 1 / max = 1</p>
<p><b>Attributes</b> See definition of companyRefType on page 25</p>	
<p><b>Semantics / Business Rules</b> Provides available official identifiers of the legal entity, CHNum being the predominant identifier.</p>	

<b>instanceType/heading/canton</b>	
<p><b>Data Type</b> cantonType</p>	<p><b>Occurrence</b> min = 1 / max = 1</p>
<p><b>Restrictions</b> -</p>	<p><b>Example Usage</b> &lt;canton&gt;VD&lt;/canton&gt;</p>
<p><b>Semantics / Business Rules</b> Cantonal Commercial Registry which made the latest entry in the citations.</p>	

<b>instanceType/heading/entityStatus</b>	
<p><b>Data Type</b> xs:int (restricted)</p>	<p><b>Occurrence</b> min = 1 / max = 1</p>
<p><b>Restrictions</b> -</p>	<p><b>Example Usage</b> &lt;entityStatus&gt;1&lt;/entityStatus&gt;</p>
<p><b>Semantics / Business Rules</b> 0 = The legal entity has been marked as "deleted". 1 = The legal entity has been marked as "active".</p>	



<b>instanceType/heading/legalForm</b>	
<b>Data Type</b> legalFormType	<b>Occurrence</b> min = 1 / max = 1
<b>Restrictions</b> See definition of legalFormType on page 90.	<b>Example Usage</b> <legalForm>3</legalForm>
<b>Semantics / Business Rules</b> Encodes the legal form of the legal entity as an integer number. For details, see the legalFormType definition on page 90.	

<b>instanceType/heading/legalFormText</b>	
<b>Data Type</b> xs:token	<b>Occurrence</b> min = 1 / max = 1
<b>Restrictions</b> -	<b>Example Usage</b> <legalFormText>Aktiengesellschaft</legalFormText>
<b>Semantics / Business Rules</b> Textual description of the legal form of the legal entity in the language specified in the lang attribute of the parent heading element.	

<b>instanceType/heading/inscriptionDate</b>	
<b>Data Type</b> xs:date	<b>Occurrence</b> min = 0 / max = 1
<b>Restrictions</b>	<b>Example Usage</b> <inscriptionDate>2002-05-18</inscriptionDate>
<b>Semantics / Business Rules</b> Date of the first inscription of the legal entity in the Commercial Registry (unchanged in case of transfer of domicile).	

<b>instanceType/heading/beginDate</b>	
<b>Data Type</b> xs:date	<b>Occurrence</b> min = 0 / max = 1
<b>Restrictions</b> -	<b>Example Usage</b> <beginDate>2002-05-19</beginDate>
<b>Semantics / Business Rules</b> If the legal form will be changed from 10 (Limited Partnership ["Kommanditgesellschaft"]) to 2 (General Partnership ["Kollektivgesellschaft"]), then the beginDate indicates the moment (point in time) when the change took effect.	

instanceType/heading/deletionDate	
<b>Data Type</b> xs:date	<b>Occurrence</b> min = 0 / max = 1
<b>Restrictions</b> -	<b>Example Usage</b> <deletionDate>2002-05-21</deletionDate>
<b>Semantics / Business Rules</b> Date when the legal entity's deletion in the registry was published.	

instanceType/heading/duration	
<b>Model</b>	
<pre> classDiagram     class duration     class BaseClass     class description     class termination     duration .. &gt; BaseClass     BaseClass &lt; -- description     BaseClass &lt; -- termination     </pre>	
<b>Data Type</b> -	<b>Occurrence</b> min = 0 / max = 1
<b>Semantics / Business Rules</b> Indicates the moment from which on the legal entity will cease to exist, either as a specific date in the future or a timely interval.	

instanceType/heading/duration/description	
<b>Data Type</b> xs:token	<b>Occurrence</b> min = 1 / max = 1
<b>Restrictions</b> -	<b>Example Usage</b> <description> Will close activites on 31-12-2015 </description>
<b>Semantics / Business Rules</b> Duration of the legal entity.	

<b>instanceType/heading/duration/termination</b>	
<b>Data Type</b> xs:date	<b>Occurrence</b> min = 1 / max = 1
<b>Restrictions</b> -	<b>Example Usage</b> <termination>2015-12-31</termination>
<b>Semantics / Business Rules</b> Duration expressed as a termination date.	

<b>instanceType/heading/transferFrom</b>	
<b>Model</b>	
<pre> classDiagram     class transferFrom     class companyRefType {         +attributes         +CHNum         +IdCantonal         +UID         +other         +link     }     class attributes {         +officeID         +date     }     transferFrom "1" *-- "1" companyRefType     companyRefType "1" .. "*" attributes     companyRefType "1" *-- "1" complexType     class complexType {         +CHNum         +IdCantonal         +UID         +other         +link     }     </pre>	
<b>Data Type</b> companyRefType	<b>Occurrence</b> min = 0 / max = 1
<b>Attributes</b> See definition of companyRefType on page 25	
<b>Semantics / Business Rules</b> Used when a carry-over has taken place. Describes the legal entity <u>before</u> the carry-over; the legal entity has a different <code>suffix</code> attribute (the <u>old</u> one) with <code>CHNum</code> , yet <code>CHNum</code> remains the same.	

**instanceType/heading/transferTo**

**Model**

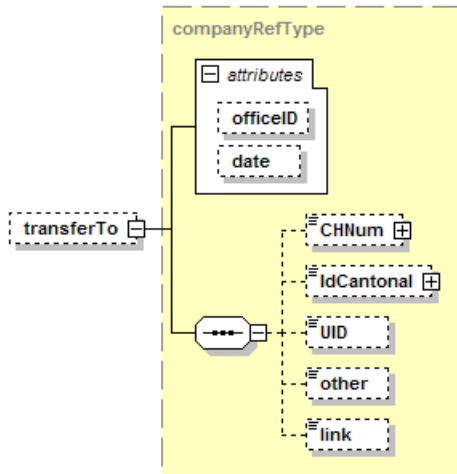

**Data Type**

companyRefType

**Occurrence**

min = 0 / max = 1

**Attributes**

See definition of companyRefType on page 25

**Semantics / Business Rules**

Used if a carry-over has happened. Describes the legal entity after the carry-over. The legal entity has a different *suffix* attribute (the new one) with CHNum, although CHNum remains the same.

**instanceType/heading/lastRef**

*Used for inter-office exchange of commercial registry data, not the excerpt*

**Data Type**

xs:int

**Occurrence**

min = 0 / max = 1

**Restrictions**

hr namespace

**Example Usage**

<hr:lastRef>35</hr:lastRef>

**Semantics / Business Rules**

Last reference number in the citation list (i.e. the highest of the numbers).

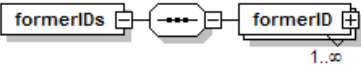
<b>instanceType/heading/formerIDs</b>	
<i>Used for inter-office exchange of commercial registry data, not the excerpt</i>	
<b>Model</b> 	
<b>Data Type</b> hr:companyRefType	<b>Occurrence</b> min = 0 / max = 1
<b>Restrictions</b> hr namespace	<b>Example Usage</b> <hr:bfs>9998</hr:bfs>
<b>Semantics / Business Rules</b> Company identifiers, which were used at the time when there was no commercial registry company number.	

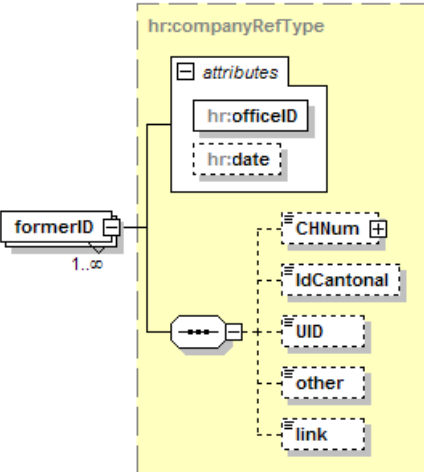
<b>instanceType/heading/formerIDs/formerID</b>	
<i>Used for inter-office exchange of commercial registry data, not the excerpt</i>	
<b>Model</b> 	
<b>Data Type</b> hr:companyRefType	<b>Occurrence</b> min = 0 / max = unbounded
<b>Restrictions</b> hr namespace	<b>Example Usage</b> <hr:formerID>1234</hr:formerID>
<b>Semantics / Business Rules</b> A particular out-dated company identifier.	

<b>instanceType/heading/timestamp</b>	
<b>Used for inter-office exchange of commercial registry data, not the excerpt</b>	
<b>Data Type</b> xs:int	<b>Occurrence</b> min = 0 / max = 1
<b>Restrictions</b> hr namespace	<b>Example Usage</b> <hr:timestamp>2009-05-28T10:18:23 </hr:timestamp>
<b>Semantics / Business Rules</b> Timestamp of the last change in the registry database.	

<b>instanceType/citations</b>	
<b>Model</b>	
<pre> classDiagram     class citations     class citation     citations "1" -- "*" citation     </pre>	
<b>Data Type</b> -	<b>Occurrence</b> min = 1 / max = 1
<b>Semantics / Business Rules</b> Every statement of facts in the excerpt is accompanied by an integer number, normally written on the left of the statement. This number is used as a reference to a row in the <i>citations table</i> . This row, in turn, specifies where in the diary the inscription (or modification, or deletion) of the particular fact took place, when and by whom. It also contains details of the publication, like the SOGC (Swiss Official Gazette of Commerce) number, date, page and the publication number.  <i>citations</i> contains as many <i>citation</i> elements as there are rows in the table.	

<b>instanceType/citations/citation</b>	
<p><b>Model</b></p>	
<p><b>Data Type</b></p> <p>-</p>	<p><b>Occurrence</b></p> <p>min = 1 / max = unbounded</p>
<p><b>Attributes</b></p> <p>ref                                    xs:int (required) → Citation number (number of row)</p>	
<p><b>Semantics / Business Rules</b></p> <p>Represents a row in the citations table.</p>	

<b>instanceType/citations/citation/canton</b>	
<p><b>Data Type</b></p> <p>cantonType</p>	<p><b>Occurrence</b></p> <p>min = 1 / max = 1</p>
<p><b>Restrictions</b></p> <p>-</p>	<p><b>Example Usage</b></p> <p>&lt;canton&gt;VD&lt;/canton&gt;</p>
<p><b>Semantics / Business Rules</b></p> <p>Canton of which the Cantonal Commercial Registry is responsible for registering information regarding a legal entity.</p>	

<b>instanceType/citations/citation/officeID</b>	
<p><b>Data Type</b></p> <p>xs:int</p>	<p><b>Occurrence</b></p> <p>min = 0 / max = 1</p>
<p><b>Restrictions</b></p> <p>See office ID codes in the table below.</p>	<p><b>Example Usage</b></p> <p>&lt;officeID&gt;550&lt;/officeID&gt;</p>
<p><b>Semantics / Business Rules</b></p> <p>Identifies the Cantonal Commercial Registry, which made a particular citation.</p>	

officeID	Office
20	ZH
36	BE
100	LU
120	UR
130	SZ
140	OW
150	NW
160	GL
170	ZG
217	FR
241	SO
270	BS
280	BL
290	SH
300	AR

officeID	Office
310	AI
320	SG
350	GR
400	AG
440	TG
501	TI
550	VD
600	VS (Oberwallis)
601	<b>reserved</b>
621	VS (Unterwallis)
626	VS (Zentralwallis)
645	NE
660	GE
670	JU

instanceType/citations/citation/diary	
<p><b>Model</b></p> <pre> classDiagram     class diary     class diaryType["diaryType (extension)"]     class attributes     class kindOfEntry     class text     class entryNr     class date     class year      diary --&gt; diaryType     diaryType -- attributes     attributes -- kindOfEntry     diaryType -- text     diaryType -- choice1[" "]     choice1 -- entryNr     choice1 -- choice2[" "]     choice2 -- date     choice2 -- year     </pre>	
<p><b>Data Type</b> diaryType</p>	<p><b>Occurrence</b> min = 0 / max = 1</p>
<p><b>Attributes</b> See definition of diaryType on page 28</p>	
<p><b>Semantics / Business Rules</b> Usually, the entry number and date (a year, exceptionally) as recorded in the diary. In rare cases, structured data is not available and thus a text is provided instead.</p>	





<b>instanceType/citations/citation/visum</b>	
<b>Used for inter-office exchange of commercial registry data, not the excerpt</b>	
<b>Data Type</b> xs:token	<b>Occurrence</b> min = 0 / max = 1
<b>Restrictions</b> hr namespace	<b>Example Usage</b> <hr:visum>MZ</hr:visum>
<b>Semantics / Business Rules</b> Initials of the person responsible for the cited record.	

<b>instanceType/rubrics</b>	
<b>Model</b>	
<b>Data Type</b> -	<b>Occurrence</b> min = 1 / max = 1
<b>Semantics / Business Rules</b> Where the excerpt's core content is located.	

<b>instanceType/rubrics/seats</b>	
<b>Model</b>	
<b>Data Type</b> -	<b>Occurrence</b> min = 1 / max = 1
<b>Semantics / Business Rules</b> Where all data about the domicile are registered.	

<b>instanceType/rubrics/seats/seat</b>	
<p><b>Model</b></p>	
<b>Data Type</b>	<b>Occurrence</b>
-	min = 1 / max = unbounded
<b>Attributes</b>	
citeGroup	See definition on page 92
<b>Semantics / Business Rules</b>	
<p>There is one <code>seat</code> element for each registered matter of fact pertaining to the legal entity's domicile. Usually, there is only one <code>seat</code> having the <code>status</code> attribute set to "1" (i.e. the current domicile).</p>	

<b>instanceType/rubrics/seats/seat/seatText</b>	
<b>Data Type</b>	<b>Occurrence</b>
xs:token	min = 1 / max = 1
<b>Restrictions</b>	<b>Example Usage</b>
-	<seatText>Bern</seatText>
<b>Semantics / Business Rules</b>	
<p>The legal entity's domicile (i.e. the name of a municipality).</p>	

<b>instanceType/rubrics/seats/seat/bfsNum</b>	
<b>Data Type</b>	<b>Occurrence</b>
bfsNumType	min = 0 / max = 1
<b>Restrictions</b>	<b>Example Usage</b>
-	<bfsNum>351</bfsNum>
<b>Semantics / Business Rules</b>	
<p>The municipality's identification number according to the Swiss Federal Statistical Office.</p>	

<b>instanceType/rubrics/seats/seat/canton</b>	
<b>Data Type</b> cantonType	<b>Occurrence</b> min = 0 / max = 1
<b>Restrictions</b> -	<b>Example Usage</b> <canton>BE</canton>
<b>Semantics / Business Rules</b> Canton in which the domicile of a legal entity is located.	

<b>instanceType/rubrics/seats/seat/country</b>	
<b>Data Type</b> countryType	<b>Occurrence</b> min = 0 / max = 1
<b>Restrictions</b> -	<b>Example Usage</b> <country>CH</country>
<b>Semantics / Business Rules</b> -	

<b>instanceType/rubrics/seats/seat/bfs</b>	
<i>Used for inter-office exchange of commercial registry data, not the excerpt</i>	
<b>Data Type</b> xs:int	<b>Occurrence</b> min = 0 / max = 1
<b>Restrictions</b> hr namespace	<b>Example Usage</b> <hr:bfs>9998</hr:bfs>
<b>Semantics / Business Rules</b> Most of the time this element corresponds to bfsNum. If a legal entity has two domiciles at the same time (e.g. UBS or Nestlé), then hr:bfs is used to identify a combined domicile like "Zürich und Basel".	

<b>instanceType/rubrics/names</b>	
<b>Model</b>	
<pre> classDiagram     class names     class name     names "1" *-- "1..∞" name         </pre>	
<b>Data Type</b> -	<b>Occurrence</b> min = 1 / max = 1
<b>Semantics / Business Rules</b> Legal entity's names.	

<b>instanceType/rubrics/names/name</b>	
<p><b>Model</b></p>	
<p><b>Data Type</b></p> <p>-</p>	<p><b>Occurrence</b></p> <p>min = 1 / max = 1</p>
<p><b>Semantics / Business Rules</b></p> <p>Particular record related to a legal entity's name.</p>	

<b>instanceType/rubrics/names/name/native</b>	
<p><b>Data Type</b></p> <p>xs:token</p>	<p><b>Occurrence</b></p> <p>min = 1 / max = 1</p>
<p><b>Attributes</b></p> <p>citeGroup                      See definition on page 92</p> <p>lang                                langType (optional) → Specifies the language of the principal name</p>	
<p><b>Restrictions</b></p>	<p><b>Example Usage</b></p> <p>&lt;native&gt;Sarastro GmbH&lt;/native&gt;</p>
<p><b>Semantics / Business Rules</b></p> <p>Legal entity's name.</p>	

<b>instanceType/rubrics/names/name/translation</b>	
<p><b>Data Type</b></p> <p>xs:token</p>	<p><b>Occurrence</b></p> <p>min = 0 / max = 1</p>
<p><b>Attributes</b></p> <p>citeGroup                      See definition on page 92</p> <p>lang                                langType (optional) → Specifies the language of the translated name</p>	
<p><b>Restrictions</b></p>	<p><b>Example Usage</b></p> <p>&lt;translation&gt;Sarastro Ltd&lt;/translation&gt;</p>
<p><b>Semantics / Business Rules</b></p> <p>Translation of the legal entity's name.</p>	

<b>instanceType/rubrics/names/name/notice</b>	
<b>Used for inter-office exchange of commercial registry data, not the excerpt</b>	
<b>Data Type</b> xs:token	<b>Occurrence</b> min = 0 / max = unbounded
<b>Attributes</b>	
hr:status	xs:int (required) → 1 = this data is actual / 0 = this is outdated information
hr:fldID	xs:int (optional) → The kind of annotation in this notice (codified)
hr:fldType	xs:string (optional) → Text describing the kind of annotation
hr:bfS	xs:int (optional) → Special purpose municipality identifier
hr:seat	xs:string(optional) → Special purpose seat information
hr:date	xs:date (optional) → Special purpose date information
hr:ins	xs:string (optional) → Insertion reference in the citation table
<b>Restrictions</b> hr namespace	<b>Example Usage</b> <pre>&lt;hr:notice status="1"&gt; Gelöscht: Publ.Dat. 25.09.2009 &lt;/hr:notice&gt;</pre>
<b>Semantics / Business Rules</b> Private data used by the information system operators of the Cantonal Commercial Registry.	

<b>instanceType/rubrics/addresses</b>	
<b>Model</b>	
<b>Data Type</b> -	<b>Occurrence</b> min = 0 / max = 1
<b>Semantics / Business Rules</b> One address must be located at the legal entity's domicile. Other addresses (without further specifications) are also allowed.	

**instanceType/rubrics/addresses/address**

**Model**

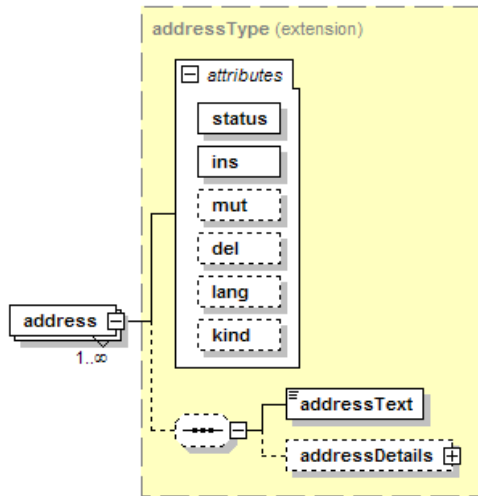

**Data Type**

addressType

**Occurrence**

min = 1 / max = unbounded

**Attributes**

See definition of addressType on page 16

**Semantics / Business Rules**

A particular address entry.

**instanceType/rubrics/purposes**

**Model**

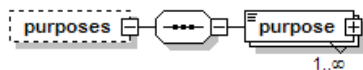

**Data Type**

-

**Occurrence**

min = 0 / max = 1

**Semantics / Business Rules**

Collection of registry records regarding the purpose of the legal entity.

<b>instanceType/rubrics/purposes/purpose</b>	
<b>Data Type</b> xs:token	<b>Occurrence</b> min = 1 / max = unbounded
<b>Attributes</b> citeGroup                      See definition on page 92	
<b>Restrictions</b> -	<b>Example Usage</b> <purpose> <b>Produktion von und Handel mit Waren</b> <b>aller Art</b> </purpose>
<b>Semantics / Business Rules</b> Purpose of the legal entity in the form of a written text.	

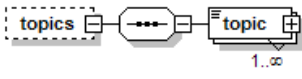
<b>instanceType/rubrics/topics</b>	
<b>Model</b> 	
<b>Data Type</b> -	<b>Occurrence</b> min = 0 / max = 1
<b>Semantics / Business Rules</b> Collection of registry records about issues and matters for which there is only textual information available.	



**instanceType/rubrics/topics/topic**

**Model**

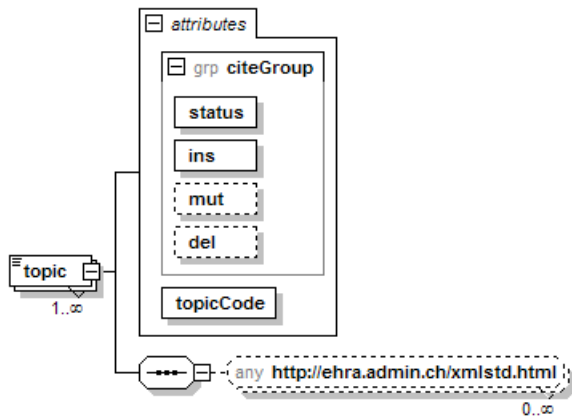

**Data Type**

**Occurrence**

min = 1 / max = unbounded

**Attributes**

citeGroup	See definition on page 92
topicCode	xs:int (required) → Specifies the domain of the topic. See table of codes below.

**Restrictions**

Use topicCode from the list of topic codes.

**Example Usage**

```
<topic topicCode="126">Die Gesellschaft ist mit Beschluss der Gesellschafter  
Versammlung vom 22.12.2004 aufgelöst.  
</topic>
```

**Semantics / Business Rules**

Topics is mostly information that cannot be registered in any other way than by text.

Code	De	Fr	It
120	Kurzzweck	résumé du but	scopo ridotto
	Angaben betreffend Übernahme von Aktiven und Passiven	Reprise des actifs et des passifs	indicazioni concernenti l'assunzione degli attivi e dei passivi
122			
123	Genussscheine	Bons de jouissance	Buoni di godimento
124	Vinkulierung	Restriction à la transmissibilité	Limizione della trasferibilità
125	Statutarische Vorrechte	Privilèges statutaires	Privilegi statuari
126 <sup>1</sup>	Mitteilungen	Communications	Comunicazioni
127	Bemerkungen	Observations	Osservazioni
128	Löschungsgrund	Motif de la radiation	Motivo della cancellazione
131 <sup>2</sup>	Bemerkungen	Observations	Osservazioni
132	Organisation	Organisation	Organizzazione
	Qualifizierte Tatbestände	Faits qualifiés	Conderimenti in natura e assunzioni di beni
133			
134	Genussscheine	Bons de jouissance	Buoni di godimento
163	Kommentar zum Kapital	Commentaire concernant le capital	Commento del capitale
180 <sup>3</sup>	Umwandlung	Transformation	Trasformazioni
	Fusion, Spaltung, Umwandlung, Vermögensübertragung	Fusion, scission, transformation, transfert de patrimoine	Fusione, scissione, trasformazione, trasferimento di patrimonio
181 <sup>4</sup>			
	Fusion, Spaltung, Umwandlung, Vermögensübertragung	Fusion, scission, transformation, transfert de patrimoine	Fusione, scissione, trasformazione, trasferimento di patrimonio
182 <sup>5</sup>			
185	Mittel	Ressources	Mezzi
	Haftung/ Nachschusspflicht	Responsabilité, prestations supplémentaires	Responsabilità/ versamenti suppletivi
186			
187	Pflichten	Obligations	Obblighi
190	Publikationsorgan	Organe de publication	Organo di pubblicazione
191	Aufsichtsbehörde	Autorité de surveillance	Autorità di vigilanza
257	Bemerkung zum Kapital	Observation relative au capital	Osservazioni relativo il capitale

<sup>1</sup>) communication to the shareholders

<sup>2</sup>) communication regarding persons

<sup>3</sup>) used only if a Limited Partnership ("Kommanditgesellschaft") transforms into a General Partnership ("Kollektivgesellschaft") or vice-versa

<sup>4</sup>) appears in the "comments" section of the printout ("Bemerkungen")

<sup>5</sup>) appears in the "contribution in kind" section of the printout ("Sacheinlage")

instanceType/rubrics/capital	
<p><b>Model</b></p>	
<p><b>Data Type</b></p> <p>-</p>	<p><b>Occurrence</b></p> <p>min = 0 / max = 1</p>
<p><b>Semantics / Business Rules</b></p> <p>Collection of registry records regarding the capital structure of the legal entity.</p>	

instanceType/rubrics/capital/capitalItem	
<p><b>Model</b></p>	
<p><b>Data Type</b></p> <p>capitalType</p>	<p><b>Occurrence</b></p> <p>min = 1 / max = unbounded</p>
<p><b>Attributes</b></p> <p>See definition of capitalType on page 18</p>	
<p><b>Semantics / Business Rules</b></p> <p>Structured description of the capital structure.</p>	

instanceType/rubrics/bylaws	
<b>Model</b>	
<b>Data Type</b>	<b>Occurrence</b>
-	min = 0 / max = 1
<b>Semantics / Business Rules</b>	
Collection of registry records about the articles of incorporation/bylaws of the legal entity.	

instanceType/rubrics/bylaws/bylaw	
<b>Model</b>	
<b>Data Type</b>	<b>Occurrence</b>
-	min = 1 / max = unbounded
<b>Attributes</b>	
citeGroup	See definition on page 92
<b>Semantics / Business Rules</b>	
Date on which the articles of incorporation/bylaws have been adopted or changed.	

instanceType/rubrics/bylaws/bylaw/date	
<b>Data Type</b>	<b>Occurrence</b>
xs:date	min = 1 / max = 1
<b>Attributes</b>	
first	xs:int (optional) → "1" = These articles of incorporation/bylaws have been published first (initial articles of incorporation/bylaws).
<b>Restrictions</b>	<b>Example Usage</b>
-	<date>2007-09-23</date>
<b>Semantics / Business Rules</b>	
-	

<b>instanceType/rubrics/bylaws/bylaw/text</b>	
<b>Data Type</b> xs:token	<b>Occurrence</b> min = 1 / max = 1
<b>Restrictions</b> -	<b>Example Usage</b> <text>23. Sept. 2007</text>
<b>Semantics / Business Rules</b> Sometimes, the date of the articles of incorporation/bylaws is only available as text.	

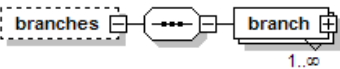
<b>instanceType/rubrics/branches</b>	
<b>Model</b> 	
<b>Data Type</b> -	<b>Occurrence</b> min = 0 / max = 1
<b>Semantics / Business Rules</b> Collection of records about the branch offices of the legal entity (if any).	

**instanceType/rubrics/branches/branch**

**Model**

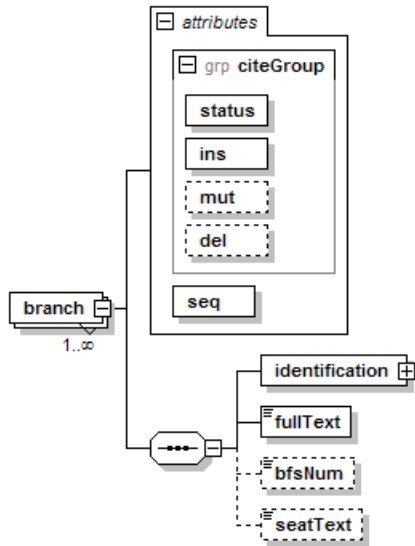

**Data Type**

-

**Occurrence**

min = 1 / max = unbounded

**Attributes**

citeGroup

See definition on page 92

seq

xs:int (required) → Specifies the sequential order in which entries with the same citation reference occur in the excerpt. Useful for declaring the order of appearance of branch registrations that have been registered on the same day.

**Restrictions**

-

**Example Usage**

-

**Semantics / Business Rules**

Records about a branch office.

<b>instanceType/rubrics/branches/branch/identification</b>	
<p><b>Model</b></p>	
<p><b>Data Type</b> companyRefType</p>	<p><b>Occurrence</b> min = 1 / max = 1</p>
<p><b>Attributes</b> See definition of companyRefType on page 25</p>	
<p><b>Restrictions</b> -</p>	<p><b>Example Usage</b> -</p>
<p><b>Semantics / Business Rules</b> Numbers or tokens used to identify the branch office.</p>	

<b>instanceType/rubrics/branches/branch/fullText</b>	
<p><b>Data Type</b> xs:token</p>	<p><b>Occurrence</b> min = 1 / max = 1</p>
<p><b>Restrictions</b> -</p>	<p><b>Example Usage</b> &lt;fullText&gt;Bern (BE)&lt;/fullText&gt;</p>
<p><b>Semantics / Business Rules</b> Domicile of the branch office. May render seatText redundant or contain additional details not found in seatText.</p>	

<b>instanceType/rubrics/branches/branch/bfsNum</b>	
<p><b>Data Type</b> bfsNumType</p>	<p><b>Occurrence</b> min = 0 / max = 1</p>
<p><b>Restrictions</b> -</p>	<p><b>Example Usage</b> &lt;bfsNum&gt;351&lt;/bfsNum&gt;</p>
<p><b>Semantics / Business Rules</b> Municipality identifier of the branch office according to the Swiss Federal Statistical Office.</p>	

instanceType/rubrics/branches/branch/seatText	
<b>Data Type</b> xs:token	<b>Occurrence</b> min = 0 / max = 1
<b>Restrictions</b> -	<b>Example Usage</b> <seatText>Bern</seatText>
<b>Semantics / Business Rules</b> Domicile of the branch office.	

instanceType/rubrics/HQinfos/HQinfo	
<b>Model</b>	
<b>Data Type</b> -	<b>Occurrence</b> min = 0 / max = 1
<b>Semantics / Business Rules</b> Information about the head office of the legal entity.	

instanceType/rubrics/HQinfos/HQinfo/HQid	
<b>Model</b>	
<b>Data Type</b> companyRefType	<b>Occurrence</b> min = 1 / max = 1
<b>Attributes</b> See definition of companyRefType on page 25	
<b>Semantics / Business Rules</b> Numbers or tokens used for identifying the head office.	



<b>instanceType/rubrics/HQinfos/HQinfo/HQtext</b>	
<b>Data Type</b> xs:token	<b>Occurrence</b> min = 1 / max = unbounded
<b>Attributes</b>	
citeGroup	See definition on page 92
infoCode	xs:int (required) → See list of codes below.
<b>Restrictions</b> -	<b>Example Usage</b> <pre>&lt;HQtext infoCode="141"&gt;   Aktiengesellschaft &lt;/HQtext&gt;</pre>
<b>Semantics / Business Rules</b>	
The infoCode attribute specifies the kind of statement , which can be found in the HQtext element.	

infoCode	De	Fr	It
140	Firma Hauptsitz	Raison de commerce du siège principal	Ditta della sede principale
141	Rechtsform Hauptsitz	Nature juridique du siège principal	Natura giuridica della sede principale
142	Hauptsitz	Siège principal	Sede principale
143	Statuten Hauptsitz	Date des statuts du siège principal	data degli statuti della sede principale
144	Registrierung Hauptsitz	Inscription au registre du commerce du siège principal	Iscrizione nel RC delle sede principale
146	Kapital Hauptsitz	Capital social au siège principal	Capitale sociale delle sede principale
147	Qualifizierte Tatbestände Hauptsitz	Faits qualifiés du siège principal	Conferimento in natura e assunzioni di beni della sede principale
148	Bekanntmachungen Hauptsitz	Publications du siège principal	Pubblicazioni della sede principale
149	Organisation Hauptsitz	Organisation du siège principal	Organizzazione della sede principale
150	Bemerkungen zum Hauptsitz	Remarques du siège principal	Osservazioni della sede principale
151	Hauptsitz in	Siège principal à	Sede principale a
152	Pflichten/ Haftung/ Nachschusspflicht Hauptsitz	Obligations/ responsabilité/ versements supplémentaires du siège principal	Obblighi/ responsabilità/ versamenti suppletivi della sede principale
153	Mittel Hauptsitz	Moyens, ressources du siège principal	Mezzi della sede principale

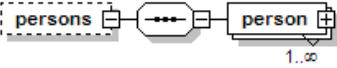
instanceType/rubrics/persons	
<p><b>Model</b></p> 	
<p><b>Data Type</b></p> <p>-</p>	<p><b>Occurrence</b></p> <p>min = 0 / max = 1</p>
<p><b>Semantics / Business Rules</b></p> <p>A collection of registered facts about persons with a function in the legal entity.</p>	

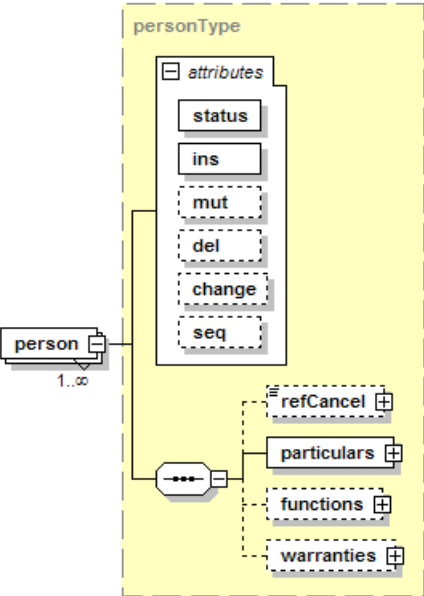
instanceType/rubrics/persons/person	
<p><b>Model</b></p> 	
<p><b>Data Type</b></p> <p>personType</p>	<p><b>Occurrence</b></p> <p>min = 1 / max = unbounded</p>
<p><b>Attributes</b></p> <p>See definition of personType on page 63</p>	
<p><b>Semantics / Business Rules</b></p> <p>Information about a registered person.</p>	

locationType	
<b>Model</b>	
<b>Appearance</b>	
excerpt/instance/rubrics/addresses/address/addressDetails	
<b>Attributes</b>	
-	
<b>Remarks</b>	
Structured data about an address or location.	

locationType/destination	
<b>Data Type</b>	<b>Occurrence</b>
xs:token	min = 0 / max = 1
<b>Restrictions</b>	<b>Example Usage</b>
-	<destination>Müller + Co.</destination>
<b>Semantics / Business Rules</b>	
The name of the recipient.	

locationType/co	
<b>Data Type</b> xs:token	<b>Occurrence</b> min = 0 / max = 1
<b>Restrictions</b> -	<b>Example Usage</b> <co>Frau Monika Meier</co>
<b>Semantics / Business Rules</b> A person or legal entity taking care of the recipient's correspondence.	

locationType/attention	
<b>Data Type</b> xs:token	<b>Occurrence</b> min = 0 / max = 1
<b>Attributes</b> attnGroup	<b>(used for inter-office exchange of commercial registry data, not the excerpt)</b> see definition on page 94
<b>Restrictions</b> -	<b>Example Usage</b> <attention>Markus Müller</attention>
<b>Semantics / Business Rules</b> The name of a person.	

locationType/street	
<b>Data Type</b> xs:token	<b>Occurrence</b> min = 0 / max = 1
<b>Restrictions</b> -	<b>Example Usage</b> <street>Bundesrain</street>
<b>Semantics / Business Rules</b> Street name.	

locationType/buildingNum	
<b>Data Type</b> xs:token (extended)	<b>Occurrence</b> min = 0 / max = 1
<b>Attributes</b> prefixed	xs:int (restricted, optional) → 1 = Print buildingNum first, then street / 0 = Otherwise
<b>Restrictions</b>	<b>Example Usage</b> <buildingNum prefixed="0"> 20 </buildingNum>
<b>Semantics / Business Rules</b> Some addresses are registered as "Bundesrain 20" and others as "15, Ave. Principale". In the latter case, the attribute prefixed has to be set to "1".	

locationType/streetAddOn	
<b>Data Type</b> xs:token	<b>Occurrence</b> min = 0 / max = 1
<b>Restrictions</b> -	<b>Example Usage</b> <streetAddOn>Châlet Bellevue </streetAddOn>
<b>Semantics / Business Rules</b> Extension to the street name.	

locationType/poBoxNum	
<b>Data Type</b> xs:token	<b>Occurrence</b> min = 0 / max = 1
<b>Restrictions</b> -	<b>Example Usage</b> <poBoxNum>395</poBoxNum>
<b>Semantics / Business Rules</b> The number of a post office box (P.O. Box). Do <b>not use</b> the P.O. Box string, like "Postfach 395" or "case postale 395".	

locationType/zip	
<b>Data Type</b> xs:token	<b>Occurrence</b> min = 0 / max = 1
<b>Restrictions</b> -	<b>Example Usage</b> <zip>3003</zip>
<b>Semantics / Business Rules</b> ZIP code.	

locationType/city	
<b>Data Type</b> xs:token	<b>Occurrence</b> min = 0 / max = 1
<b>Restrictions</b> -	<b>Example Usage</b> <city>Bern</city>
<b>Semantics / Business Rules</b> Name of the municipality or part of a municipality.	

<b>locationType/country</b>	
<b>Data Type</b> countryType	<b>Occurrence</b> min = 0 / max = 1
<b>Restrictions</b> -	<b>Example Usage</b> <country>CH</country>
<b>Semantics / Business Rules</b> Country code according to ISO 3166-1 (2 alpha characters).	

<b>locationType/bfsNum</b>	
<b>Data Type</b> bfsNumType	<b>Occurrence</b> min = 0 / max = 1
<b>Restrictions</b> -	<b>Example Usage</b> <bfsNum>351</bfsNum>
<b>Semantics / Business Rules</b> Municipality identifier according to the Swiss Federal Statistical Office.	

<b>locationType/cantonalLocNum</b>	
<b>Data Type</b> xs:token	<b>Occurrence</b> min = 0 / max = 1
<b>Restrictions</b> -	<b>Example Usage</b> <cantonalLocNum>4711</cantonalLocNum>
<b>Semantics / Business Rules</b> Location identifier according to Cantonal identification numbers.	

<b>locationType/federalLocNum</b>	
<b>Data Type</b> xs:token	<b>Occurrence</b> min = 0 / max = 1
<b>Restrictions</b> -	<b>Example Usage</b> <federalLocNum>1234</federalLocNum>
<b>Semantics / Business Rules</b> Location identifier according to Federal identification numbers.	

**personType**

**Model**

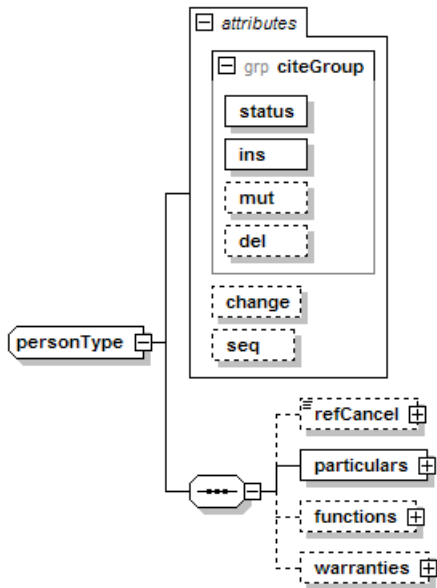

**Appearance**

excerpt/instance/rubrics/persons/person

**Attributes**

citeGroup	See definition on page 92
change	xs:int (optional) → 1 = The delete column contains a citation reference with a letter "m". See remarks for details. 0 = otherwise
seq	xs:int (optional) → If more than one person is reported at the same time (i.e. their ins or mut values are the same) then seq indicates the order of appearance.

**Remarks**

From a technical viewpoint, a person is an object with properties. The person as such – the object – must be identified uniquely throughout the lifetime of all records in the registry. Only then it is possible to trace the person's "vita" in the excerpt accurately. The properties of a person include all mutable items, like origin, function, warranty and family name. Each time an item is changed, the new item must be registered while the obsolete one, if any, is removed. If, for example, John Doe, formerly a *Board Member* becomes the new *Board Director*, then the record holding the item *Board Member* would be marked as deleted and a new record for *Board Director* introduced. As a result, the mutation has led to the deletion of obsolete data.

In order to be accurate, the excerpt must clarify what kind of action is responsible for the deletion of an old record. Is it a strict "delete" or just the consequence of a "mutation" action? In order to accomplish the required transparency, every record that was marked as "deleted" due to a mutation action tells you so by an extra "m" letter appended to the citation number in the delete row. This helps clarifying the difference between the deletion of an item and the deletion of the person as such. If the person was deleted, no "m" letter appears.

In our previous example, the record saying John Doe is a *Board Member* would be marked with an "m" in the delete row (the number in this row is the citation number of the new record saying *Board Director*).

personType/refCancel	
<b>Data Type</b> xs:token	<b>Occurrence</b> min = 0 / max = 1
<b>Attributes</b> ins                      xs:int (required) → References the citation number of the inscription seq                        xs:int (optional) → Specify the ordering, if more than one are found in the same ins value. Indirectly points to the line number in a sequence of equal citation numbers.	
<b>Restrictions</b>	<b>Example Usage</b> <refCancel>21</refCancel>
<b>Semantics / Business Rules</b> refCancel is used to specify the citation that was affected by a mutation. That citation (the line) has now got a "m" letter to indicate that the change was in fact a mutation, not a deletion (although the citation is crossed out)	

personType/particulars	
<b>Model</b>	
<b>Data Type</b> -	<b>Occurrence</b> min = 1 / max = 1
<b>Attributes</b> personKind      xs:int (required) → 1 = physical person / 2 = company underage        xs:int (optional) → 1 = person is underage / 0 = otherwise. patronised       xs:int (optional) → 1 = person is patronised / 0 = otherwise.	
<b>Semantics / Business Rules</b> Details about a person, either a legal entity or a physical person.	



personType/particulars/identification	
<p><b>Model</b></p>	
<p><b>Data Type</b> companyRefType</p>	<p><b>Occurrence</b> min = 0 / max = 1</p>
<p><b>Attributes</b> See definition of companyRefType on page 25</p>	
<p><b>Semantics / Business Rules</b> Numbers or tokens used to identify the legal entity.</p>	

personType/particulars/PID	
<p><b>Data Type</b> xs:token</p>	<p><b>Occurrence</b> min = 0 / max = 1</p>
<p><b>Attributes</b> hr:pid</p>	<p><i>(used for inter-office exchange of commercial registry data, not the excerpt)</i> xs:token (optional)</p>
<p><b>Restrictions</b> -</p>	<p><b>Example Usage</b> &lt;name&gt;Fabro AG&lt;/name&gt;</p>
<p><b>Semantics / Business Rules</b> Official identifier of a physical person, if available.</p>	

personType/particulars/name	
<p><b>Data Type</b> xs:token</p>	<p><b>Occurrence</b> min = 1 / max = 1</p>
<p><b>Attributes</b> hr:prefix</p>	<p><i>(used for inter-office exchange of commercial registry data, not the excerpt)</i> xs:token (optional) → A prefix to the person's name, like "de" or "von".</p>
<p><b>Restrictions</b> -</p>	<p><b>Example Usage</b> &lt;name&gt;Fabro AG&lt;/name&gt;</p>
<p><b>Semantics / Business Rules</b> In case of a legal entity, this is the legal entity's name. In case of a physical person, this is the last name.</p>	

<b>personType/particulars/mrMrs</b>	
<b>Data Type</b> xs:int (restricted)	<b>Occurrence</b> min = 0 / max = 1
<b>Restrictions</b> min. value = 1, max. value = 3	<b>Example Usage</b> <mrMrs>1</mrMrs>
<b>Semantics / Business Rules</b> 1: Miss or Mrs. (a female person) 2: Mr (a male person) 3: Unknown or not applicable	

<b>personType/particulars/title</b>	
<b>Data Type</b> xs:token	<b>Occurrence</b> min = 0 / max = 1
<b>Restrictions</b> -	<b>Example Usage</b> <title>President</title>
<b>Semantics / Business Rules</b> A person's title or function.	

<b>personType/particulars/firstName</b>	
<b>Data Type</b> xs:token	<b>Occurrence</b> min = 1 / max = 1
<b>Restrictions</b> -	<b>Example Usage</b> <firstName>Hans Ulrich</firstName>
<b>Semantics / Business Rules</b> A physical person's first name.	

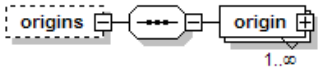
<b>personType/particulars/origins</b>	
<b>Model</b> 	
<b>Data Type</b> -	<b>Occurrence</b> min = 0 / max = 1
<b>Semantics / Business Rules</b> A list of places of origin.	

<b>personType/particulars/origins/origin</b>	
<p><b>Model</b></p>	
<p><b>Data Type</b></p> <p>-</p>	<p><b>Occurrence</b></p> <p>min = 1 / max = unbounded</p>
<p><b>Semantics / Business Rules</b></p> <p>Description of a place of origin. A place of origin in Switzerland is registered differently from that in a foreign country.</p>	

<b>personType/particulars/origins/origin/city</b>	
<p><b>Data Type</b></p> <p>xs:token</p>	<p><b>Occurrence</b></p> <p>min = 1 / max = 1</p>
<p><b>Restrictions</b></p> <p>-</p>	<p><b>Example Usage</b></p> <p>&lt;city&gt;Zürich&lt;/city&gt;</p>
<p><b>Semantics / Business Rules</b></p> <p>Place of origin.</p>	

<b>personType/particulars/origins/origin/bfsNum</b>	
<b>Data Type</b> countryType	<b>Occurrence</b> min = 0 / max = 1
<b>Restrictions</b> -	<b>Example Usage</b> <bfsNum>261</bfsNum>
<b>Semantics / Business Rules</b> Municipality identifier according to the Swiss Federal Statistical Office.	

<b>personType/particulars/origins/origin/country</b>	
<b>Data Type</b> countryType	<b>Occurrence</b> min = 0 / max = 1
<b>Restrictions</b> -	<b>Example Usage</b> <country>DE</country>
<b>Semantics / Business Rules</b> Country code according to ISO 3166-1 (2 alpha characters).	

<b>personType/particulars/origins/origin/phrase</b>	
<b>Data Type</b> xs:token	<b>Occurrence</b> min = 1 / max = 1
<b>Restrictions</b> -	<b>Example Usage</b> <phrase>Deutsche Staatsangehörige</phrase>
<b>Semantics / Business Rules</b> A text describing the citizenship of a foreign person.	

<b>personType/particulars/origins/origin/adjective</b>	
<b>Used for inter-office exchange of commercial registry data, not the excerpt</b>	
<b>Data Type</b> xs:token	<b>Occurrence</b> min = 0 / max = 1
<b>Restrictions</b> -	<b>Example Usage</b> <phrase>deutsch</phrase>
<b>Semantics / Business Rules</b> Adjective to simplify the construction of grammatically correct text with regard to the nationality of a person.	

<b>personType/particulars/residence</b>	
<b>Model</b>	
<b>Data Type</b>	<b>Occurrence</b>
-	min = 1 / max = 1
<b>Semantics / Business Rules</b>	
Describes a place of residence. Alternatively, the domicile of a company.	

<b>personType/particulars/residence/city</b>	
<b>Data Type</b>	<b>Occurrence</b>
xs:token	min = 1 / max = 1
<b>Restrictions</b>	<b>Example Usage</b>
-	<city>Zürich</city>
<b>Semantics / Business Rules</b>	
Name of the municipality of the residence.	

<b>personType/particulars/residence/zip</b>	
<b>Data Type</b>	<b>Occurrence</b>
xs:token	min = 0 / max = 1
<b>Restrictions</b>	<b>Example Usage</b>
-	<zip>8052</zip>
<b>Semantics / Business Rules</b>	
Zip code of the residence.	

<b>personType/particulars/residence/bfsNum</b>	
<b>Data Type</b>	<b>Occurrence</b>
bfsNumType	min = 0 / max = 1
<b>Restrictions</b>	<b>Example Usage</b>
-	<bfsNum>351</bfsNum>
<b>Semantics / Business Rules</b>	
Municipality identifier according to the Swiss Federal Statistical Office.	

<b>personType/particulars/residence/country</b>	
<b>Data Type</b> countryType	<b>Occurrence</b> min = 0 / max = 1
<b>Restrictions</b> -	<b>Example Usage</b> <country>CH</country>
<b>Semantics / Business Rules</b> Country code according to ISO 3166-1 (2 alpha characters).	

<b>personType/particulars/yearOfBirth</b>	
<b>Data Type</b> xs:gYear	<b>Occurrence</b> min = 0 / max = 1
<b>Restrictions</b> -	<b>Example Usage</b> <yearOfBirth>1965</yearOfBirth>
<b>Semantics / Business Rules</b> Year of birth of the person.	

<b>personType/particulars/personText</b>	
<b>Data Type</b> xs:string	<b>Occurrence</b> min = 0 / max = 1
<b>Restrictions</b> -	<b>Example Usage</b> <personText>Böckli, Prof. Dr. Peter, von Frauenfeld, in Binningen</personText>
<b>Semantics / Business Rules</b> Text describing the person's characteristics (e.g. domicile, place of birth).	

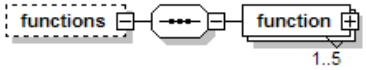
<b>personType/functions</b>	
<b>Model</b> 	
<b>Data Type</b> -	<b>Occurrence</b> min = 0 / max = 1
<b>Semantics / Business Rules</b> List of functions of a person, including the authority to sign.	

personType/functions/function	
<p><b>Model</b></p>	
<p><b>Data Type</b></p>	<p><b>Occurrence</b> min = 1 / max = 5</p>
<p><b>Attributes</b></p> <p>order                      xs:int (optional) → List of the functions of a person, representing a function hierarchy. The lower the number, the higher the function in the hierarchy.</p>	
<p><b>Semantics / Business Rules</b></p> <p>Function of a person.</p>	

personType/functions/function/funcCode	
<p><b>Data Type</b> xs:int</p>	<p><b>Occurrence</b> min = 0 / max = 1</p>
<p><b>Restrictions</b> -</p>	<p><b>Example Usage</b> &lt;funcCode&gt;3&lt;/funcCode&gt;</p>
<p><b>Semantics / Business Rules</b></p> <p>Specifies the function independently of the language of the excerpt. See table below.</p>	

funcCode	De	Fr	It
	<b>Verwaltungsfunktion</b>	<b>fonction administrative</b>	<b>funzione amministrativa</b>
100	Freier Text	texte libre	testo libero
101	Präsident	président du conseil	presidente
102	Chairman of the Board	Chairman of the Board	Chairman of the Board
110	Obmann	président du conseil	
111	Obfrau	présidente du conseil	
120	Vizepräsident	vice-président du conseil	vice-presidente
121	Vice Chairman of the Board	Vice Chairman of the Board	Vice Chairman of the Board
130	Delegierter	délégué	delegato
131	Sekretär	secrétaire	segretario
132	Protokollführer	rédacteur du procès verbal	segretario
133	Kassier	trésorier	tesoriere
134	Kassier	caissier	cassiere
135	Rechnungsführer	comptable	contabile
140	Aktuar	actuaire	
141	Quästor	questeur	
142	Beisitzer	assesseur	
150	Mitglied	Membre	membro
151	Mitglied	administrateur	amministratore
152	Einziges Mitglied	administrateur unique	amministratore unico
160	Inhaber	titulaire	titolare
161	Kommanditär	commanditaire	accomandante
162	Komplementär	complémentaire	accomandatario
170	Unbeschränkt haft. Gesellschafter	associé indéfiniment responsable	accomandatario
171	Geschäftsführer	gérant	gerente
172	Gesellschafter	associé	socio
173	Suppleant	suppléant	Supplente
180	Vorsitzender der Geschäftsführung	président des gérants	presidente dei geranti
190	Liquidator	liquidateur	liquidatore
191	Konkursliquidator	liquidateur de faillite	liquidatore
192	Ausseramtlicher Konkursverwalter	administrateur de faillite	liquidatore
193	Vertreter des Komplementärs	substitut du complémentaire	Rappresentante dell'accomandatario

(continued on the next page)



funcCode	De	Fr	It
	<b>Übrige Funktionen</b>	<b>Autres fonctions</b>	<b>altre funzioni</b>
200	Freier Text	texte libre	testo libero
220	Stellvertretender Geschäftsführer	gérant adjoint	gerente aggiunto
231	Sekretär (Nichtmitglied)	secrétaire (hors conseil)	segretario (fuori dal consiglio di amministrazione)
232	Protokollführer (Nichtmitglied)	rédacteur du procès verbal (hors conseil)	segretario (fuori dal consiglio di amministrazione)
233	Kassier (Nichtmitglied)	trésorier (hors conseil)	tesoriere (fuori dal consiglio di amministrazione)
234	Kassier (Nichtmitglied)	caissier (hors conseil)	cassiere (fuori dal consiglio di amministrazione)
235	Rechnungsführer (Nichtmitglied)	comptable (hors conseil)	contabile (fuori dal consiglio di amministrazione)
240	Aktuar (Nichtmitglied)	actuaire (hors conseil)	
241	Quästor (Nichtmitglied)	questeur (hors conseil)	
250	Generaldirektor	Directeur général	direttore generale
251	Stellvertretender Generaldirektor	directeur général adjoint	direttore generale aggiunto
252	Direktor	directeur	Direttore
253	Stellvertretende Direktor	directeur adjoint	Direttore aggiunto
254	Vizedirektor	vice directeur	vice-direttore
255	Subdirektor	sous directeur	vice-direttore
256	Direktor der Zweigniederlassung	directeur de la succursale	direttore della succursale
257	Mitglied der Direktion	membre du comité de direction, membre de la direction	membro della direzione
260	Geschäftsführer der Zweigniederlassung	gérant de la succursale	gerente della succursale
261	Vorsitzender der Direktion	Président de la direction	presidente della direzione
262	Vorsitzender der Geschäftsleitung	président de la direction	presidente della direzione
263	Mitglied der Geschäftsleitung	membre de la direction	membro della direzione
264	Bankleiter	gérant de la banque	
265	Bankleiter-Stellvertreter	Gérant adjoint de la banque	
271	Geschäftsführer (Nichtmitglied)	Gérant (hors conseil)	gerente (fuori dal consiglio di amministrazione)
272	Geschäftsführer	Gérant	gerente
273	Leiter	Chef	responsabile
274	Leiter der Zweigniederlassung	responsable de la succursale	responsabile della succursale
280	Generalsekretär	secrétaire général	segretario generale
281	Beistand	curateur	curatore
282	Zeichnungsberechtigt	ayant droit de signer	
283	Prokurist	Fondé de procuration	procuratore
	<b>Revision</b>	<b>Révision</b>	
300	Freier Text	texte libre	testo libero
310	Revisionsstelle	organe de révision	ufficio di revisione
311	Revisionsstelle mit begrenztem Mandat	organe de révision avec mandat restreint	
312	Revisionsstelle gemäss KAG	organe de révision selon LPCC	ufficio di revisione secondo LICol
313	Gerichtlich festgelegte Revisionsstelle	réviseur désigné par le juge	

<b>personType / functions / function / funcText</b>	
<b>Data Type</b> xs:token	<b>Occurrence</b> min = 0 / max = 1
<b>Attributes</b> extra                      xs:string (optional) → More information about the function. Normally used when too much text is required to specify the entire function description in funcText.	
<b>Restrictions</b> -	<b>Example Usage</b> <pre>&lt;funcText extra="des Verwaltungsrats"&gt;   Präsident &lt;/funcText&gt;</pre>
<b>Semantics / Business Rules</b> Specifies the function in the form of text (in the language of the excerpt).	

<b>personType / functions / function / authorisation</b>	
<b>Model</b>	
<b>Data Type</b> -	<b>Occurrence</b> min = 0 / max = 1
<b>Semantics / Business Rules</b> Specifies the authority to sign on behalf of the legal entity	

<b>personType / functions / function / authorisation / authCode</b>	
<b>Data Type</b> xs:int	<b>Occurrence</b> min = 1 / max = 1
<b>Restrictions</b> -	<b>Example Usage</b> <pre>&lt;authCode&gt;412&lt;/authCode&gt;</pre>
<b>Semantics / Business Rules</b> Specifies the authority to sign regardless of the language of the excerpt. See table below.	

authCode	De	Fr	It
400	Freier Text	text libre	testo libero
411	Einzelunterschrift	signature individuelle	firma individuale
412	Kollektivunterschrift zu zweien	signature collective à deux	firma collettiva a due
413	Kollektivunterschrift zu dreien	signature collective à trois	firma collettiva a tre
414	Kollektivunterschrift zu vieren	signature collective à quatre	firma collettiva a quattro
415	Kollektivunterschrift zu fünfen	signature collective à cinq	firma collettiva a cinque
421	Einzelprokura	procuration individuelle	procura individuale
422	Prokura zu zweien	procuration collective à deux	procura collettiva a due
423	Prokura zu dreien	procuration collective à trois	procura collettiva a tre
424	Prokura zu vieren	procuration collective à quatre	procura collettiva a quattro
425	Prokura zu fünfen	procuration collective à cinq	procura collettiva a cinque
431	Einzelprokura gem. OR 459	procuration individuelle selon 459 CO	procura individuale secondo 459 CO
432	Prokura gem. OR 459 zu zweien	procuration collective à deux selon 459 CO	procura collettiva a due secondo 459 CO
433	Prokura gem. OR 459 zu dreien	procuration collective à trois selon 459 CO	procura collettiva a tre secondo 459 CO
434	Prokura gem. OR 459 zu vieren	procuration collective à quatre selon 459 CO	procura collettiva a quattro secondo 459 CO
435	Prokura gem. OR 459 zu fünfen	procuration collective à cinq selon 459 CO	procura collettiva a cinque secondo 459 CO
440	ohne Zeichnungsberechtigung	sans signature	senza firma
450	Vertreten durch ihre Zeichnungsberechtigten	représenté par leurs ayants droit selon RC	

<b>personType/functions/function/authorisation/authText</b>	
<b>Data Type</b>	<b>Occurrence</b> min = 1 / max = 1
<b>Restrictions</b>	<b>Example Usage</b> <authText> <b>Kollektivunterschrift zu zweien</b> </authText>
<b>Semantics / Business Rules</b> Specifies the authority to sign as a text (in the language of the excerpt).	

<b>personType/functions/function/authorisation/extraCode</b>	
<b>Data Type</b> xs:int	<b>Occurrence</b> min = 0 / max = 1
<b>Restrictions</b> -	<b>Example Usage</b> <extraCode> <b>512</b> </extraCode>
<b>Semantics / Business Rules</b> A code that specifies the authority to sign in more detail (often a restriction to authCode / authText). See table below.	

extraCode	De	Fr	It
500	Freier Text	texte libre	testo libero
511	Beschränkt auf den Hauptsitz	limité au siège principal	limitato alla sede principale
512	Beschränkt auf die Zweigniederlassung	limité à la succursale	limitato alla succursale
513	Als Liquidator	comme liquidateur	come liquidatore
514	Gemäss OR 459 Abs. 2	selon CO 459 al. 2	secondo 459 cpv. 2 CO
515	Mit Einschränkung	avec restrictions	con limitazioni
516	Mit einem Mitglied	avec un administrateur	con un membro
517	Mit dem Präsidenten	avec le président	con il presidente
518	Mit dem Präsidenten oder Vizepräsidenten	avec le président ou le vice-président	con il presidente o il vice-presidente
519	Nicht mit einem Prokuristen	pas avec un fondé de procuration	non con un procuratore

<b>personType/functions/function/authorisation/extraText</b>	
<b>Data Type</b> xs:token	<b>Occurrence</b> min = 0 / max = 1
<b>Restrictions</b> -	<b>Example Usage</b> <extraText> <b>Beschränkt auf die Zweigniederlassung</b> </extraText>
<b>Semantics / Business Rules</b> Specifies restrictions or details of the authority to sign as a text (in the language of the excerpt).	

<b>personType/functions/function/authorisation/signShort</b>	
<b>Used for inter-office exchange of commercial registry data, not the excerpt</b>	
<b>Data Type</b> xs:token	<b>Occurrence</b> min = 0 / max = 1
<b>Restrictions</b> hr namespace	<b>Example Usage</b> <signShort>KU zu zweien</signShort>
<b>Semantics / Business Rules</b> Abbreviated specification of an authority to sign.	

<b>personType/functions/function/authorisation/extraShort</b>	
<b>Used for inter-office exchange of commercial registry data, not the excerpt</b>	
<b>Data Type</b> xs:token	<b>Occurrence</b> min = 0 / max = 1
<b>Restrictions</b> hr namespace	<b>Example Usage</b> <extraShort>K2</extraShort>
<b>Semantics / Business Rules</b> Shortened abbreviation of the specification of an authority to sign.	

<b>personType / functions / function / funcShort</b>	
<i>Used for inter-office exchange of commercial registry data, not the excerpt</i>	
<b>Data Type</b> xs:token	<b>Occurrence</b> min = 0 / max = 1
<b>Restrictions</b> hr namespace	<b>Example Usage</b> <funcShort>Präsident</funcShort>
<b>Semantics / Business Rules</b> Abbreviation of the description of the function.	

<b>personType / warranties</b>	
<b>Model</b>	
<b>Data Type</b> -	<b>Occurrence</b> min = 0 / max = 1
<b>Semantics / Business Rules</b> Liabilities of a person (e.g. limited partners have a liability which is limited to the amount of a fixed capital contribution called limited partners' contribution).	

personType/warranties/warranty	
<p><b>Model</b></p>	
<p><b>Data Type</b></p> <p>-</p>	<p><b>Occurrence</b></p> <p>min = 1 / max = unbounded</p>
<p><b>Attributes</b></p> <p>restrictions      xs:int (optional) →                      1 = Transferability of assets is restricted in some way                      0 = Otherwise</p>	
<p><b>Restrictions</b></p> <p>-</p>	<p><b>Example Usage</b></p> <p>-</p>
<p><b>Semantics / Business Rules</b></p> <p>'warranty' defines the amount, quantity, value, currency etc. of the liability.</p>	

personType/warranties/warranty/warrantyCode	
<p><b>Data Type</b></p> <p>xs:int</p>	<p><b>Occurrence</b></p> <p>min = 1 / max = 1</p>
<p><b>Restrictions</b></p> <p>-</p>	<p><b>Example Usage</b></p> <p>&lt;warrantyCode&gt;4&lt;/warrantyCode&gt;</p>
<p><b>Semantics / Business Rules</b></p> <p>A code that specifies the kind of liability. See table below.</p>	

warranty Code	De	Fr	It
600	Freier Text	texte libre	testo libero
604	Stammeinlage	part sociale	quote sociali
610	Kommanditsumme	commandite	capitale accomandato

<b>personType/warranties/warranty/warrantyText</b>	
<b>Data Type</b> xs:token	<b>Occurrence</b> min = 0 / max = 1
<b>Restrictions</b> -	<b>Example Usage</b> <warrantyText> <b>Kommanditsumme</b> </warrantyText>
<b>Semantics / Business Rules</b> Specifies the kind of liability (in the language of the excerpt).	

<b>personType/warranties/warranty/amount</b>	
<b>Data Type</b> xs:decimal	<b>Occurrence</b> min = 1 / max = 1
<b>Restrictions</b> -	<b>Example Usage</b> <amount>10000</amount>
<b>Semantics / Business Rules</b> Total amount of the liabilities.	

<b>personType/warranties/warranty/quantity</b>	
<b>Data Type</b> xs:int	<b>Occurrence</b> min = 0 / max = 1
<b>Restrictions</b> -	<b>Example Usage</b> <quantity>10</quantity>
<b>Semantics / Business Rules</b> Number of assets, e.g. shares.	

<b>personType/warranties/warranty/value</b>	
<b>Data Type</b> xs:decimal	<b>Occurrence</b> min = 0 / max = 1
<b>Restrictions</b> -	<b>Example Usage</b> <value>1000</value>
<b>Semantics / Business Rules</b> Value of a single asset (share).	



<b>personType/warranties/warranty/currency</b>	
<b>Data Type</b> currencyType	<b>Occurrence</b> min = 0 / max = 1
<b>Restrictions</b> -	<b>Example Usage</b> <currency>CHF</currency>
<b>Semantics / Business Rules</b> Currency.	

<b>personType/warranties/warranty/votingRights</b>	
<b>Data Type</b> xs:token	<b>Occurrence</b> min = 0 / max = 1
<b>Restrictions</b> -	<b>Example Usage</b> <votingRights> Stimmrechtsaktie </votingRights>
<b>Semantics / Business Rules</b> A text specifying the voting rights linked to a voting share.	

<b>personType/warranties/warranty/privileges</b>	
<b>Data Type</b> xs:token	<b>Occurrence</b> min = 0 / max = 1
<b>Restrictions</b> -	<b>Example Usage</b> <privileges> Vorzugsaktie </privileges>
<b>Semantics / Business Rules</b> A text specifying the privileges linked to a share.	

SHABType	
<p><b>Model</b></p>	
<p><b>Appearance</b></p> <p>excerpt/instance/citations/citation/SHAB</p>	
<p><b>Attributes</b></p> <p>kindOfEntry            xs:token (restricted, optional) →                                    N (normal):        Ordinary entry                                    R (rectification): Entry rectifies a previous one                                    C (complement): Entry complements an existing one                                    P (carryover):    Indicates a carryover from a previous file card.</p>	
<p><b>Remarks</b></p> <p>Describes the part of the citation that deals with the publication in the SOGC (Swiss Official Gazette of Commerce). In most cases, shabNum and date are used to specify the publication.</p>	

SHABType / text	
<p><b>Data Type</b></p> <p>xs:token</p>	<p><b>Occurrence</b></p> <p>min = 1 / max = 1</p>
<p><b>Restrictions</b></p> <p>-</p>	<p><b>Example Usage</b></p> <p>&lt;text&gt;Auslassung&lt;/text&gt;</p>
<p><b>Semantics / Business Rules</b></p> <p>In some cases the carry-over from the old-fashioned paper-based records to modern computers left some of the data records with ambiguous or incomplete content. text can overcome this difficulty by providing information that otherwise would not fit into the scheme. Its use always indicates that there was a problem with the provisioning of either the shabNum or both date and year.</p>	

SHABType / shabNum	
<p><b>Data Type</b></p> <p>xs:int</p>	<p><b>Occurrence</b></p> <p>min = 1 / max = 1</p>
<p><b>Restrictions</b></p> <p>-</p>	<p><b>Example Usage</b></p> <p>&lt;shabNum&gt;247&lt;/shabNum&gt;</p>
<p><b>Semantics / Business Rules</b></p> <p>The SOGC (Swiss Official Gazette of Commerce)'s edition number.</p>	

SHABType / page	
<b>Data Type</b> xs:int	<b>Occurrence</b> min = 0 / max = 1
<b>Restrictions</b> -	<b>Example Usage</b> <page>31</page>
<b>Semantics / Business Rules</b> The page number in the SOGC (Swiss Official Gazette of Commerce) publication.	

SHABType / pubNum	
<b>Data Type</b> xs:int	<b>Occurrence</b> min = 0 / max = 1
<b>Restrictions</b> -	<b>Example Usage</b> <pubNum>2045230</pubNum>
<b>Semantics / Business Rules</b> Publications are numbered consecutively.	

SHABType / date	
<b>Data Type</b> xs:date	<b>Occurrence</b> min = 1 / max = 1
<b>Restrictions</b> -	<b>Example Usage</b> <shabNum>2003-12-23</shabNum>
<b>Semantics / Business Rules</b> Date of publication in the SOGC (Swiss Official Gazette of Commerce).	

SHABType / year	
<b>Data Type</b> xs:gYear	<b>Occurrence</b> min = 1 / max = 1
<b>Restrictions</b> -	<b>Example Usage</b> <year>2003</year>
<b>Semantics / Business Rules</b> year is only provided exceptionally when the exact date is not known. This can happen with old records used for the setup of the electronic SOGC (Swiss Official Gazette of Commerce) database.	

<b>bfsNumType</b>	
<b>Appearance</b>	
<p>excerpt/instance/rubrics/seats/seat/bfsNum  excerpt/instance/rubrics/branches/branch/bfsNum  addressType/bfsNum  personType/particulars/company/bfsNum  personType/particulars/human/origins/origin/bfsNum  personType/particulars/human/residence/bfsNum</p>	
<b>Data Type</b>	<b>Restrictions</b>
xs:int (restricted)	maxInclusive value = "9999"
<b>Attributes</b>	
-	
<b>Semantics / Business Rules</b>	
Specifies the municipality identifier according to the Swiss Federal Statistical Office.	

<b>cantonType</b>	
<b>Appearance</b>	
<p>excerpt/instance/citations/citation/canton  excerpt/instance/heading/canton  excerpt/instance/rubrics/seats/seat/canton</p>	
<b>Data Type</b>	<b>Restrictions</b>
xs:token (enumeration)	<p>length value = "2"</p> <p>enumeration AG  enumeration AR  enumeration AI  enumeration BL  enumeration BS  enumeration BE  enumeration FR  enumeration GE  enumeration GL  enumeration GR  enumeration JU  enumeration LU  enumeration NE  enumeration NW  enumeration OW  enumeration SH  enumeration SZ  enumeration SO  enumeration SG  enumeration TI  enumeration TG  enumeration UR  enumeration VD  enumeration VS  enumeration ZG  enumeration ZH</p>
<b>Attributes</b>	
-	
<b>Semantics / Business Rules</b>	
Canton's official two-character abbreviation.	

<b>CHNumType</b>	
<b>Appearance</b> companyRefType/CHNum	
<b>Data Type</b> xs:token	<b>Restrictions</b> pattern value="CH-\d{3}\.\d\.\d{3}\.\d{3}-\d(\w*)?"
<b>Attributes</b> -	
<b>Semantics / Business Rules</b> Specifies the numbering scheme of the official Cantonal Commercial Registry number.	

<b>countryType</b>	
<b>Appearance</b>	
<p>excerpt/instance/rubrics/seats/seat/country</p> <p>addressType/country</p> <p>personType/particulars/human/origins/origin/country</p> <p>personType/particulars/human/residence/country</p> <p>personType/particulars/company/seatCountry</p>	
<b>Data Type</b>	<b>Restrictions</b>
xs:token (restricted)	length value = "2"
<b>Attributes</b>	
-	
<b>Semantics / Business Rules</b>	
Specifies the country according to the two-character abbreviation defined in the ISO standards 3166-1 (e.g. CH for Switzerland, DE for Germany, ....)	

<b>currencyType</b>	
<b>Appearance</b> personType/warranties/warranty/currency Attribute currency in type capitalType	
<b>Data Type</b> xs:string (restricted)	<b>Restrictions</b> length value = "3"
<b>Attributes</b> -	
<b>Semantics / Business Rules</b> Specifies the currency according to the three-character ISO 4217 standards (3 characters).	



<b>langType</b>	
<b>Appearance</b>	
Attribute lang in excerpt/envelope	
Attribute lang in excerpt/instance/heading	
Attribute lang in excerpt/instance/rubrics/names/name/native	
Attribute lang in excerpt/instance/rubrics/names/name/translation	
Attribute lang in addressType	
<b>Data Type</b>	<b>Restrictions</b>
xs:token (restricted)	length value = "2"
<b>Attributes</b>	
-	
<b>Semantics / Business Rules</b>	
Specifies the language according to the ISO 4166 standard (2 characters).	

<b>legalFormType</b>	
<b>Appearance</b> excerpt/instance/heading/legalForm	
<b>Data Type</b> xs:int (restricted)	<b>Restrictions</b> maxInclusive value = "99"
<b>Attributes</b> -	
<b>Semantics / Business Rules</b> Legal form of the legal entity as a code. See table below.	

legalForm	De	Fr	It
1	Einzelunternehmen	Entreprise individuelle	Ditta individuale
2	Kollektivgesellschaft	Société en nom collectif	Società in nome collettivo
3	Aktiengesellschaft (AG)	Société anonyme (SA)	Società anonima
4	Gesellschaft mit beschränkter Haftung	Société à responsabilité limitée	Società a garanzia limitata
5	Genossenschaft	Société coopérative	Società cooperativa
6	Verein	Association	Associazione
7	Stiftung	Fondation	Fondazione
8	Besondere Rechtsformen	Natures juridiques particulières	Natura giuridica particolare
9	Schweizerische Zweigniederlassung	Succursale suisse	Succursale svizzere
10	Kommanditgesellschaft	Société en commandite	Società in accomandita
11	Ausländische Zweigniederlassung	Succursale étrangère	Succursale straniera
12	Kommanditaktien-gesellschaft	Société en commandite par actions	società in accomandita per azioni
13	Institute des öffentlichen Rechts	Instituts de droit publique	istituto di diritto pubblico
14	Gemeinderschaft	Communauté / indivision	comunione / indivisione
15	SICAV	SICAV	SICAV
16	SICAF	SICAF	SICAF
17	Kommanditgesellschaft für kollektive Kapitalanlagen	Société en commandite de placements collectifs	società in accomandita per investimenti collettivi di capitale
18	Nicht kaufmännische Prokura	Procuration non commerciale	procura non commerciale

<b>UIDtype</b>	
<b>Appearance</b> companyRefType/UID	
<b>Data Type</b> xs:token (restricted)	<b>Restrictions</b> Not specified in the schema.  Reason: Although the format of the number is known, it is highly uncertain how people will write down this number.
<b>Attributes</b> -	
<b>Semantics / Business Rules</b> Specifies the identification number of the legal entity according to the Swiss Federal Statistical Office.	

<b>citeGroup (Attribute Group)</b>	
<p><b>Appearance</b></p> <p>Attribute Group of the following:</p> <pre> excerpt/instance/rubrics/branches/branch excerpt/instance/rubrics/bylaws/bylaw excerpt/instance/rubrics/HQinfos/HQinfo/HQtext excerpt/instance/rubrics/names/name/native excerpt/instance/rubrics/names/name/translation excerpt/instance/rubrics/purposes/purpose excerpt/instance/rubrics/seats/seat excerpt/instance/rubrics/topics/topic  addressType capitalType personType                     </pre>	
<p><b>Remarks</b></p> <p>This attribute group specifies the current status of the registered matter of fact in the registry as well as the citations record that it references.</p>	
<p><b>Attribute Member</b></p> <p>status (xs:int, restricted) minInclude = "0" maxInclude="1"</p>	<p><b>Semantics</b></p> <p>The current status in the registry, either "active" (status = "1") or "deleted" (status = "2")</p>
<p><b>Attribute Member</b></p> <p>ins (xs:int)</p>	<p><b>Semantics</b></p> <p>Refers to the "inscription" row in the citations. An inscription is the first action each time a new matter of fact is introduced.</p>
<p><b>Attribute Member</b></p> <p>mut (xs:int)</p>	<p><b>Semantics</b></p> <p>Refers to the "mutations" row in the citations. A mutation action in a specific place in the table induces an entry with an "m" in the "delete" row of an earlier record (referencing a fact that was already present and which is affected by the mutation, but not deleted as such).</p>
<p><b>Attribute Member</b></p> <p>del (xs:int)</p>	<p><b>Semantics</b></p> <p>Refers to the "deletions" row in the citations.</p> <p>An entry without an appended "m" indicates that the registered fact has changed status from "active" to "deleted" by virtue of the publication referenced by row number del.</p> <p>If the entry carries an "m" with the del number, this indicates that the fact is related to a person's property, like name, function or authorisation. Note that in this case, the person as such is not deleted.</p>

<b>hr : companyRefType</b>
<i>Used for inter-office exchange of commercial registry data, not the excerpt</i>
<p><b>Model</b></p> <pre> classDiagram     class companyRefType {         attributes {             hr:officeID             hr:date         }         CHNum         IdCantonal         UID         other         link     }     </pre>
<p><b>Appearance</b></p> <p>excerpt / instance / heading / formerIDs / formerID</p>
<p><b>Attributes</b></p> <p>hr:officeID            xs:token (required) → Office that assigned the formerID</p> <p>hr:date                xs:data (optional) → Date when this formerID was assigned</p>
<p><b>Remarks</b></p> <p>The same as companyRefType, except for the attributes.</p>

<b>hr : CHNumType</b>
<i>Used for inter-office exchange of commercial registry data, not the excerpt</i>
<p><b>Appearance</b></p> <p>excerpt / instance / heading / formerIDs / formerID / CHNum</p>
<p><b>Remarks</b></p> <p>The same as CHNumType.</p>

<b>hr : UIDType</b>
<i>Used for inter-office exchange of commercial registry data, not the excerpt</i>
<p><b>Appearance</b></p> <p>excerpt / instance / heading / formerIDs / formerID / UID</p>
<p><b>Remarks</b></p> <p>The same as UIDType.</p>

<b>hr:attnGroup (Attribute Group)</b>	
<i>Used for inter-office exchange of commercial registry data, not the excerpt</i>	
<b>Appearance</b> Attribute Group of the following: excerpt/instance/locationType/attention	
<b>Remarks</b> This attribute group provides internal knowledge about some details of a person referenced in attention	
<b>Attribute Member</b> hr:title (xs:token, required)	<b>Semantics</b> A person's title
<b>Attribute Member</b> hr:firstName (xs:token, required)	<b>Semantics</b> A person's first name.
<b>Attribute Member</b> lastName (xs:token, required)	<b>Semantics</b> A person's last name.

# Part IV

## Glossary (English – German – French – Italian)

English	Deutsch	Français	It
assets	Wertgegenstände, Güter	actifs, biens	attivi
authorisation	(Zeichnungs) Berechtigung	pouvoir de représentation	poteri di rappresentanza
bearer share	Inhaberaktie	action au porteur	azioni al portatore
branch	Zweigniederlassung	succursale	succursale
bylaws	Statuten	statuts	statuti
capital structure	Kapitalstruktur	structure du capital	stuttura del capitale
cash-in capital	Liberiertes Kapital	capital libéré	capitale liberato
citations table	Zitatliste	index des citations (glossaire)	glossario
contribution in kind	Sacheinlage	apport en nature	conferimento in natura
commercial registry	Handelsregister	registre du commerce	registro di commercio
commercial registry number	Firmennummer des Handelsreg.	numéro d'identification du (RC)	numero di identificazione
commercial registry office	Handelsregisteramt	office du registre du commerce	ufficio del registro di commercio
commune	Gemeinde	commune	comune
competence	Zuständigkeit	compétence	competenza
cooperative society	Genossenschaft	société coopérative	società cooperativa
currency	Währung	monnaie	moneta
deletion	Löschung	radiation	cancellazione
diary	Tagesregister	registre journalier	registro giornaliero
division	Stückelung	division	divisione
(commercial registry) excerpt	(Handelsregister-) Auszug	extrait du registre du commerce	estratto del registro di commercio
(matter of) facts	Tatbestände	faits	fatti
federal commercial registry office	Eidg. Amt für das Handelsregister	office fédéral du registre du commerce	ufficio federale del registro di commercio
file cards	Karteikarten	fiches analytiques	cartellino
function	Funktion	fonction	funzione
heading of the excerpt	Kopfzeile	en-tête	occhiello
headquarter	Hauptsitz	siège principal	sede principale
legal person	Juristische Person	personne morale	persona giuridica
legislation	Gesetzgebung	législation	legislazione
Limited commercial partnership	Kommanditgesellschaft	société en commandite	società in accomandita
mutation	Änderung, Mutation	modifications	modificazioni
origin	Heimatort	lieu d'origine	luogo d'origine
physical person	Natürliche Person	personne physique	persona fisica
privileges	Vorrechte	droits de priorité	diritti di preferenza
publication	Bekanntmachung, Publikation	publication	pubblicazione
purpose	Zweck	but	scopo
registered share	Namenaktie	actions nominatives	azioni nominative
registration	Eintragung	inscription	iscrizione
residence	Wohnsitz	domicile	domicilio
(legal) seat	Sitz	siège	sede
shareholder	Aktionär	actionnaire	azionista
topics	Besondere Tatbestände	faits particuliers	fatti speciali
unlimited partnership	Kollektivgesellschaft	société en nom collectif	società in nome collettivo
voting rights	Stimmrecht	droit de vote	diritto di voto
warranty	Garantie	garantie	garanzia

**License Information**

This schema is free of charge and may be used and distributed freely.

**Publisher:**

Federal Department of Justice and Police FDJP  
**Federal Office of Justice FOJ**  
Federal Commercial Registry Office FCRO

Bundesrain 20, CH-3003 Berne, Switzerland  
Phone +41 31 322 41 96  
Fax +41 31 322 44 83  
ehra@bj.admin.ch  
<http://www.zefix.ch/>