



# Evaluation und gouvernementales Lernen im Rahmen von Konferenzen und Workshops - die “Lernspirale” in Theorie und Praxis

Dr. Raoul Blindenbacher, Berater EDA und BJ

Netzwerk Evaluation in der Bundesverwaltung

8. Juni 2011; 10.30 – 12.15 Uhr

# Content

1. World Bank Group WBG at a Glance
2. Independent Evaluation Group IEG at a Glance
3. Analytical Considerations
4. Theoretical Considerations
5. Template “Governmental Learning Spiral”
6. Practical Application
7. Conclusions

# 1. WBG at a Glance: History

1. Marshall Plan/European Recovery Program 1944 -
2. Decolonization in Asia and Africa 1950 –
3. Fall of Iron Curtain 1989 –
4. Globalization 2000 –

# 1. WBG at a Glance: Branches

1. The International Bank for Reconstruction and Development IBRD (1946/48)
2. The International Finance Corporation IFC (1956)
3. The International Development Association IDA (1960)
4. The International Centre for Settlement of Investment Disputes (1966)
5. The Multilateral Investment Guarantee Agency MIGA (1988)

# 1. WBG at a Glance: Branches

- 1. The International Bank for Reconstruction and Development IBRD (1946/48)**
2. The International Finance Corporation IFC (1956)
- 3. The International Development Association IDA (1960)**
4. The International Centre for Settlement of Investment Disputes (1966)
5. The Multilateral Investment Guarantee Agency MIGA (1988)

# 1. WBG at a Glance: Structure/Matrix

Structure: Member Countries, Board of Governors, Board of Directors, President, Management and Staff/Support Staff

## Six Regions

		AFR	SAP	ECA	LCR	MNA	SAR
Four Sectors	HDN						
	SDN						
	PREM						
	FPD						

## 2. IEG at a Glance: Organization

1. History: Established 1973 as Operations Evaluation Department OED, since 2005 IEG
2. Task: Evaluation of WB, IFC (1996) and MIGA (2002) activities
3. Structure: The Director-General of IEG reports directly to the World Bank Group's Board of Directors

## 2. IEG at a Glance: Products

Sector and Thematic Reviews, Regional and Global Reviews, Country Assistance and Project Evaluations, Cluster Evaluations, Emergency Response, Evaluation Capacity Building, Corporate Evaluations

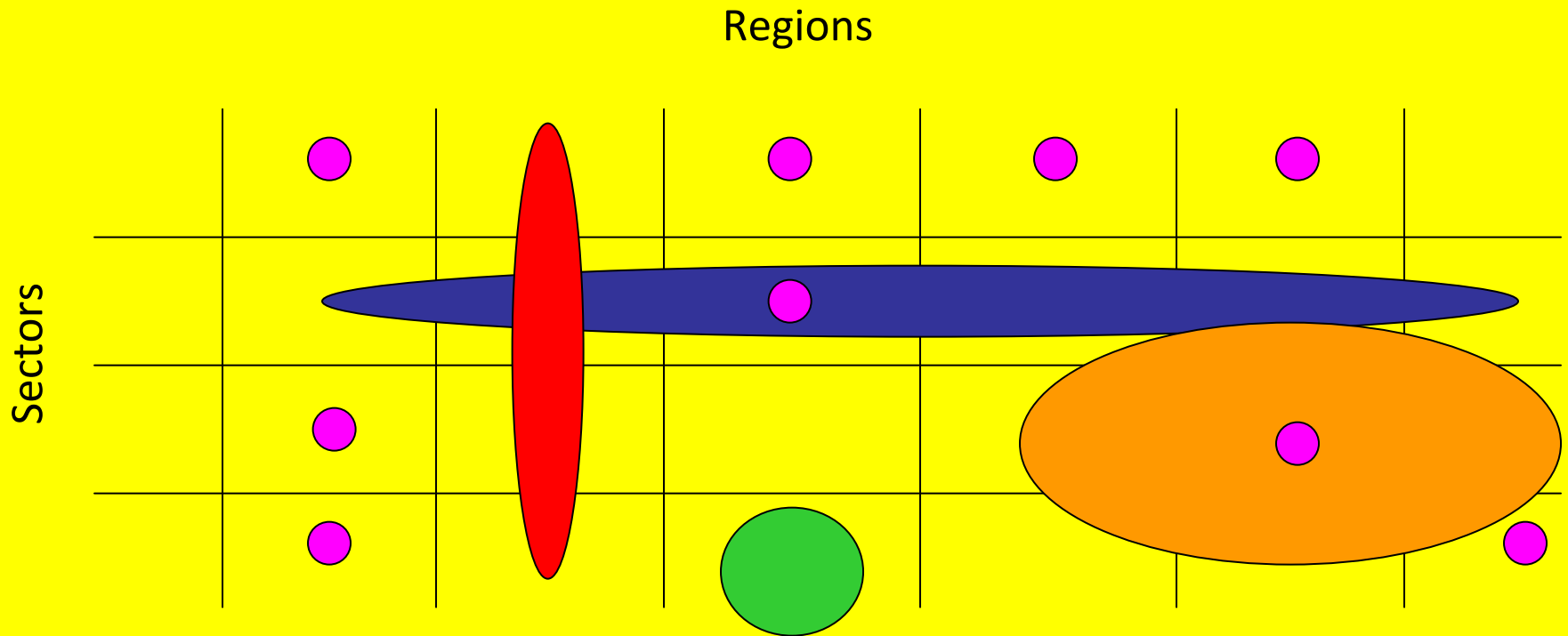



## 2. IEG at a Glance: Methods

1. Review of self-evaluation reports prepared by WBG staff and supplemented by independent assessments
2. Document Analysis (Reviews of Literature, Project Documentation)
3. Case Studies
4. Structured Interviews and Surveys of Staff and Stakeholders
5. Impact Evaluations

## 2. IEG at a Glance: Methods

- 1. Review of self-evaluation reports prepared by WBG staff and supplemented by independent assessments**
2. Document Analysis (Reviews of Literature, Project Documentation)
3. Case Studies
4. Structured Interviews and Surveys of Staff and Stakeholders
5. Impact Evaluations

## 2. IEG at a Glance: From OPE to IEG

### Change of Paradigm 2005

**OED:** Providing an objective assessment of the results of the WBG work – *Accountability* (looking backwards)

**IEG:** and to improve result in the future - *Learning* (looking forward)

### 3. Analytical Considerations: WBG Activity Cycle

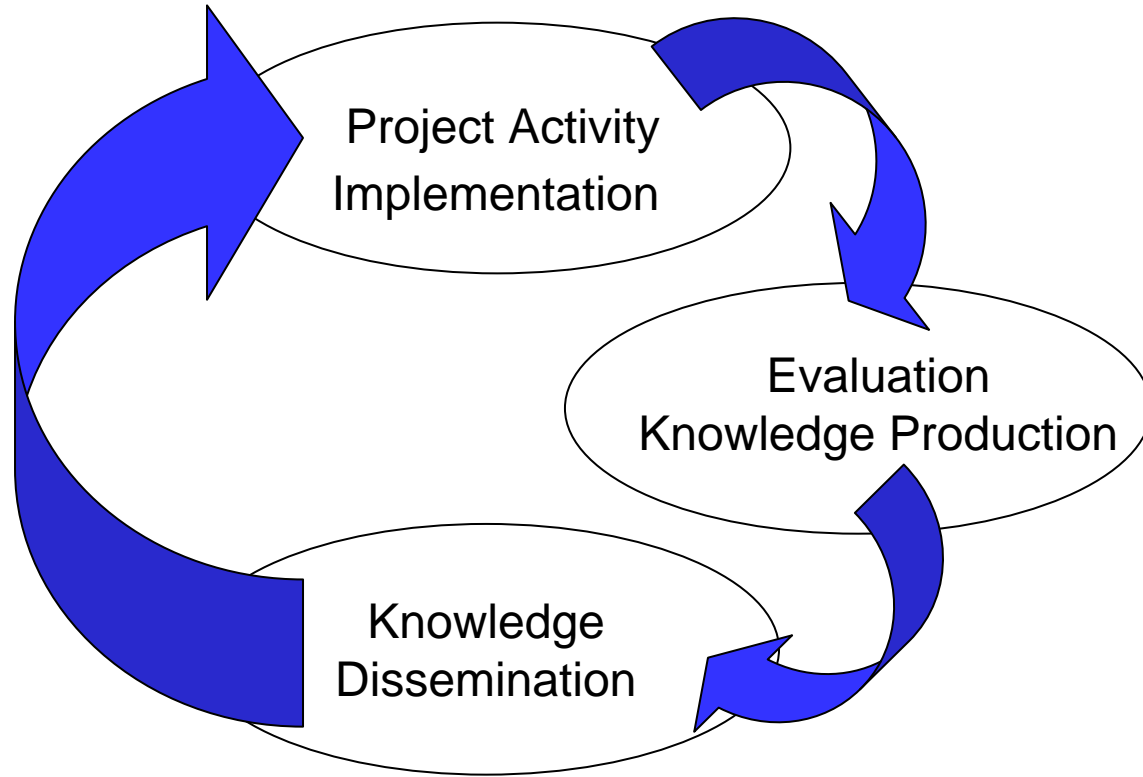

# 3. Analytical Considerations: WBG Activity Cycle

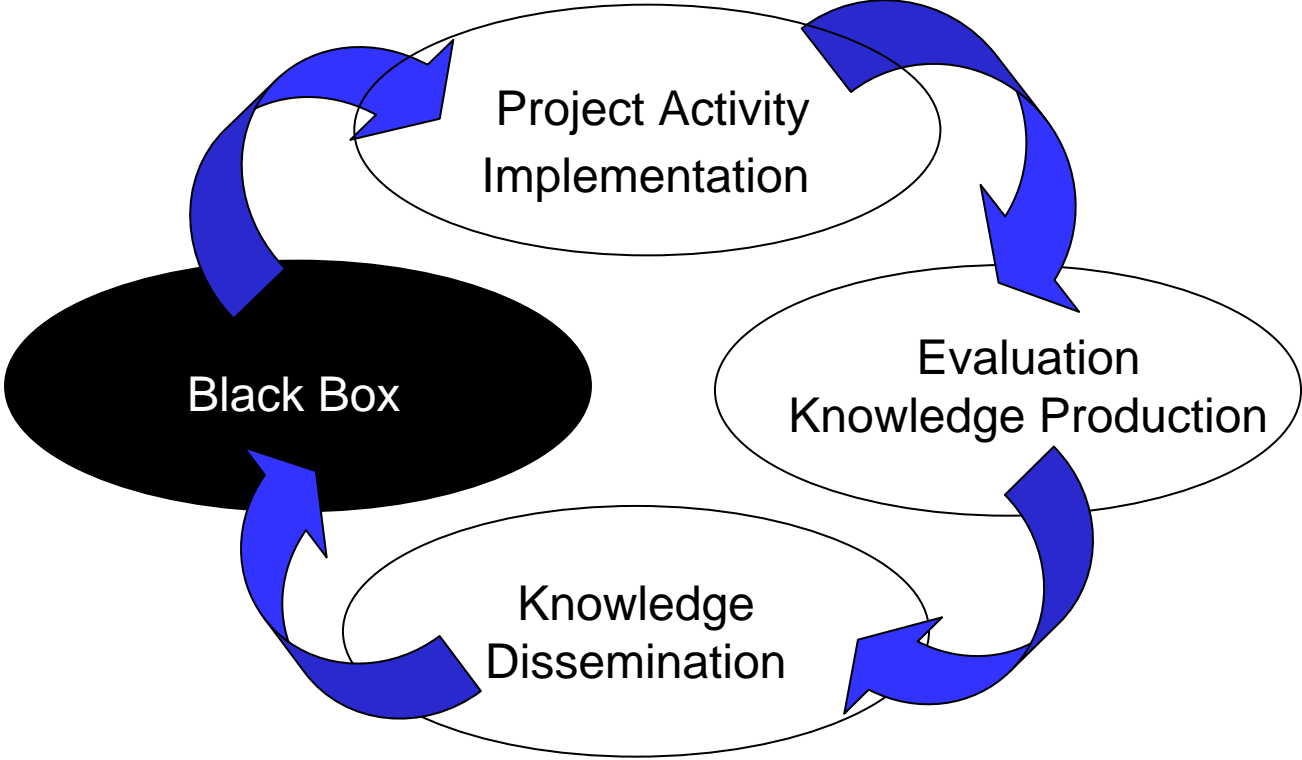

# 3. Analytical Considerations: WBG Activity Cycle

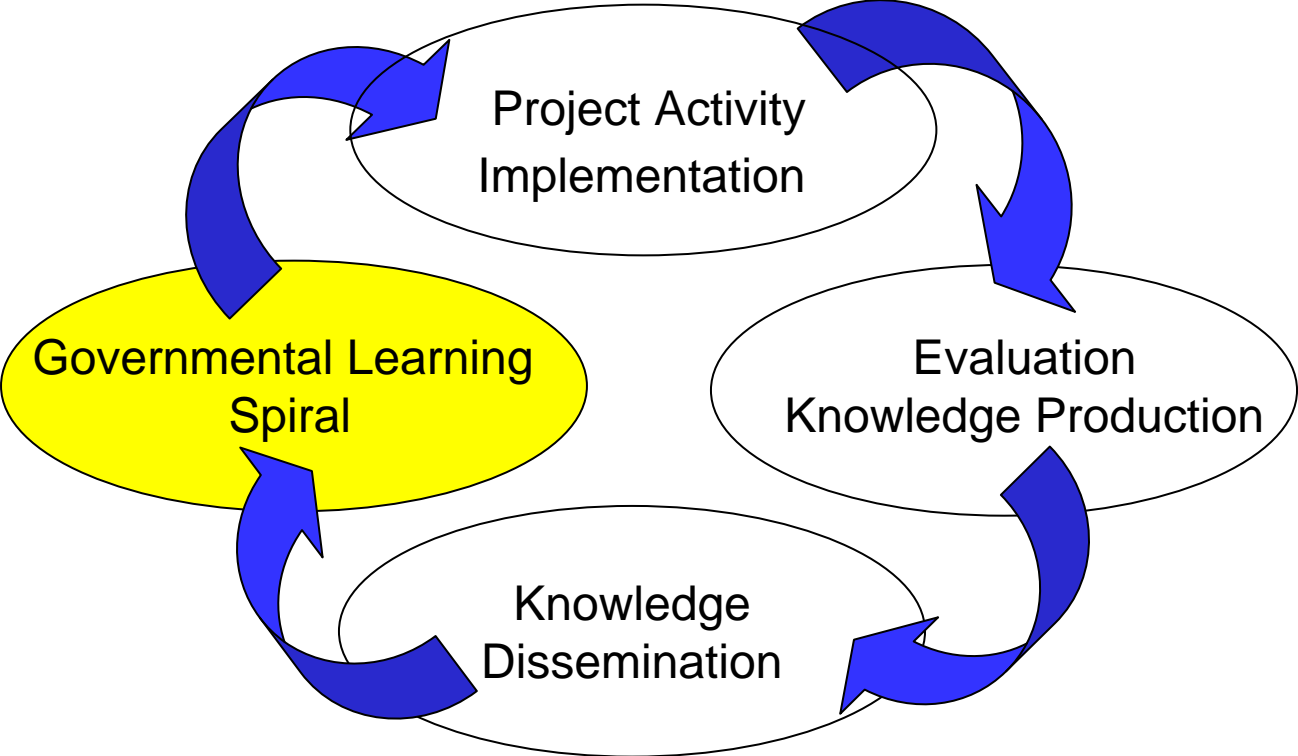

# 4. Theoretical Considerations: Kaleidoscope

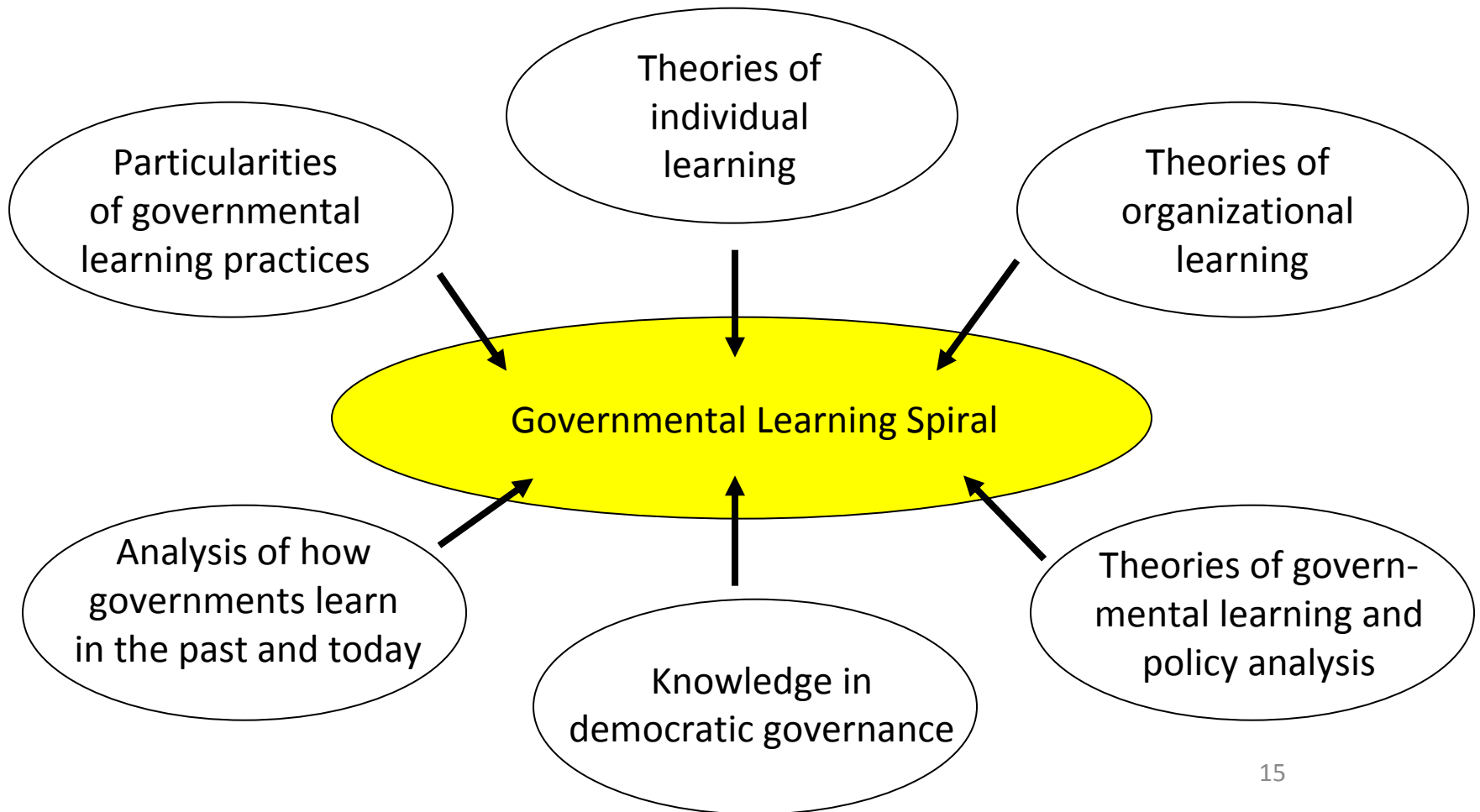

# 4. Theoretical Considerations: Kaleidoscope

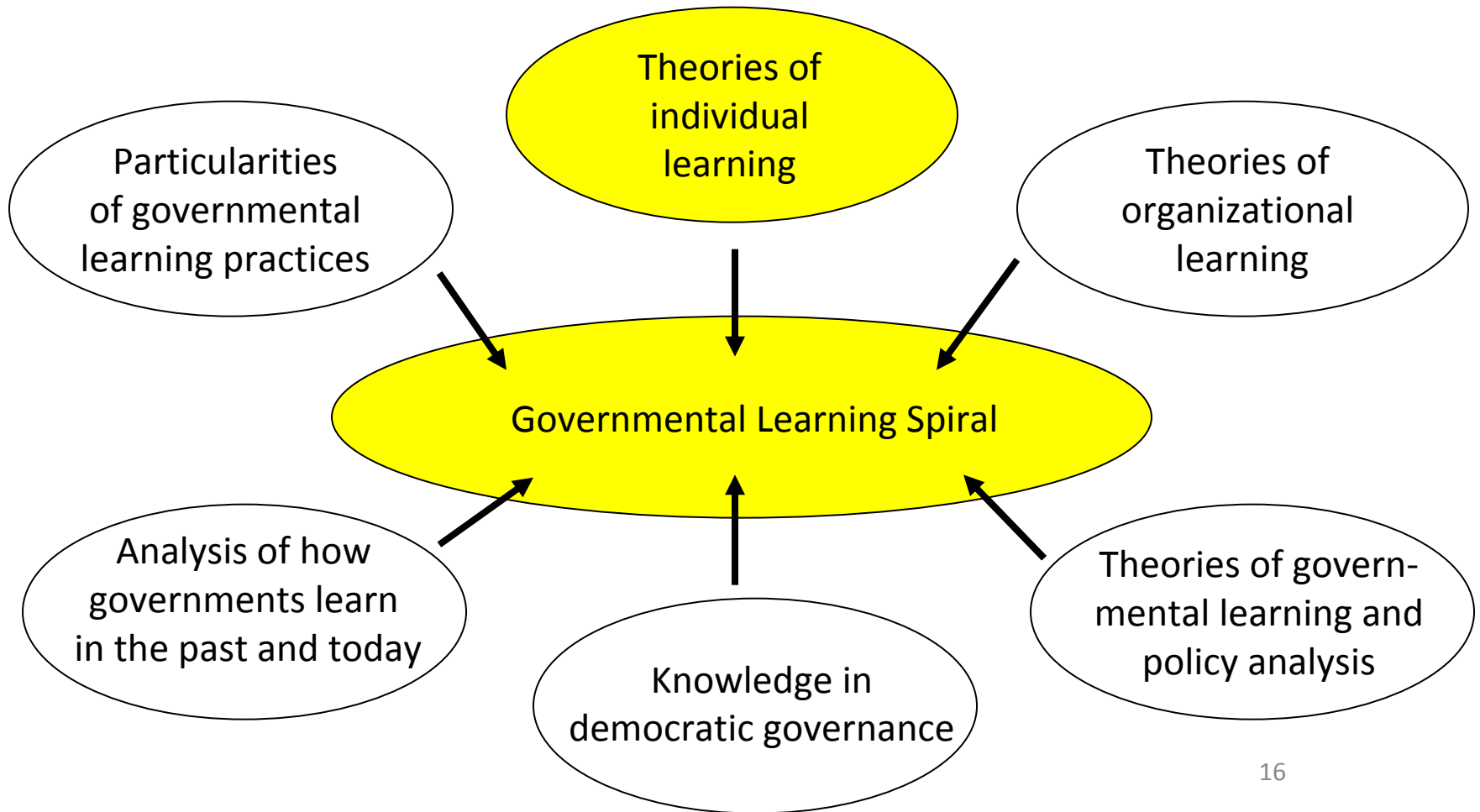



# 4. Theoretical Considerations: Individual Learning Theories

	Internal Stimulus	External Stimulus
Informal, Unstructured Learning	<b>Humanist Approach</b> Learning through intrinsic motivation <i>"curiosity"</i> Maslow/Rogers	<b>Social Approach</b> Learning through Interaction <i>"inspiration"</i> Meed/Dewey
Formalized, Structured Learning	<b>Cognitive Approach</b> Learning through discrepancies <i>"discovery, difference"</i> Lewin/Piaget	<b>Behavioral Approach</b> Learning through appropriate incentives <i>"incentives"</i> Pavlov/Skinner

# 4. Theoretical Considerations: Kaleidoscope

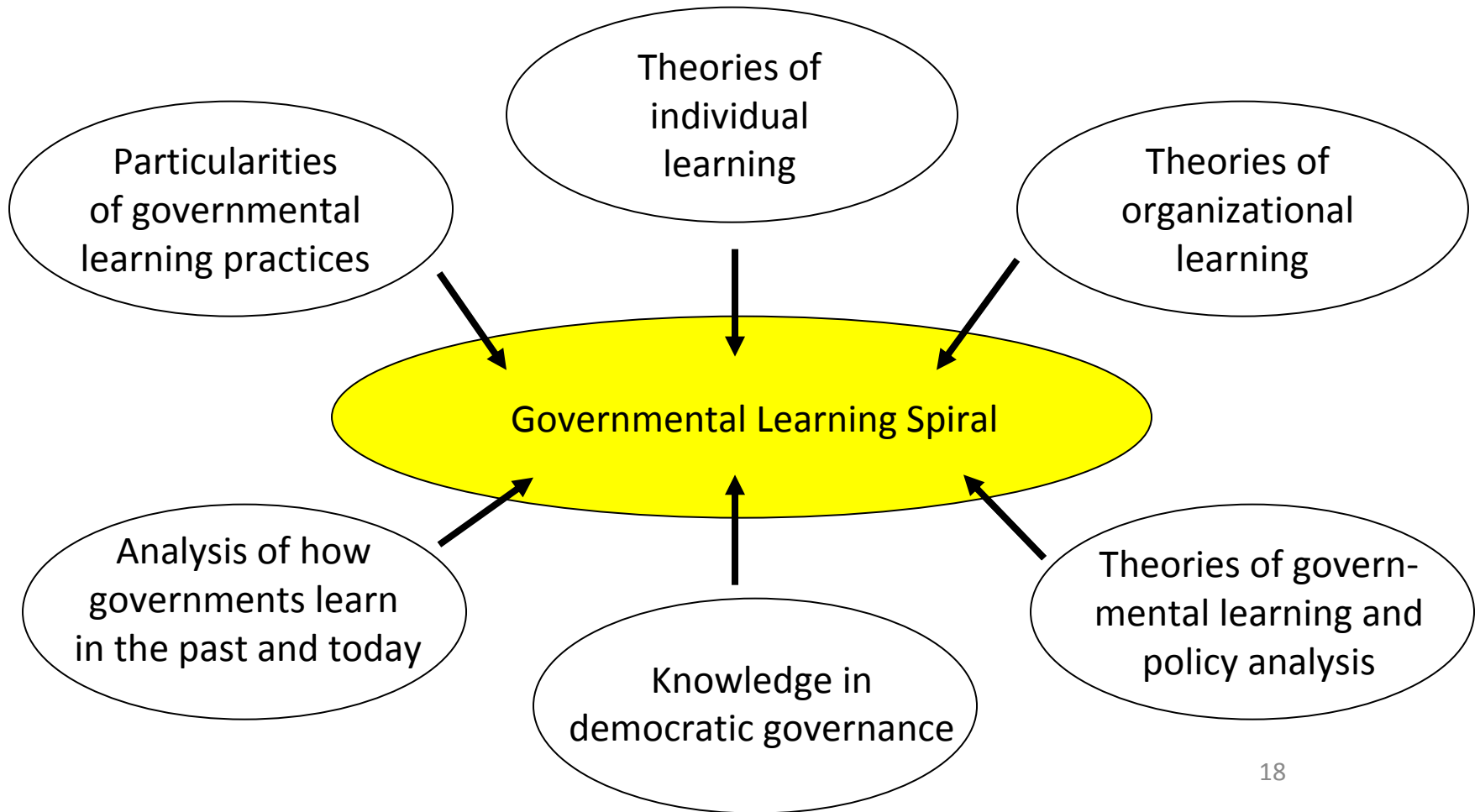

# 4. Theoretical Considerations: Kaleidoscope

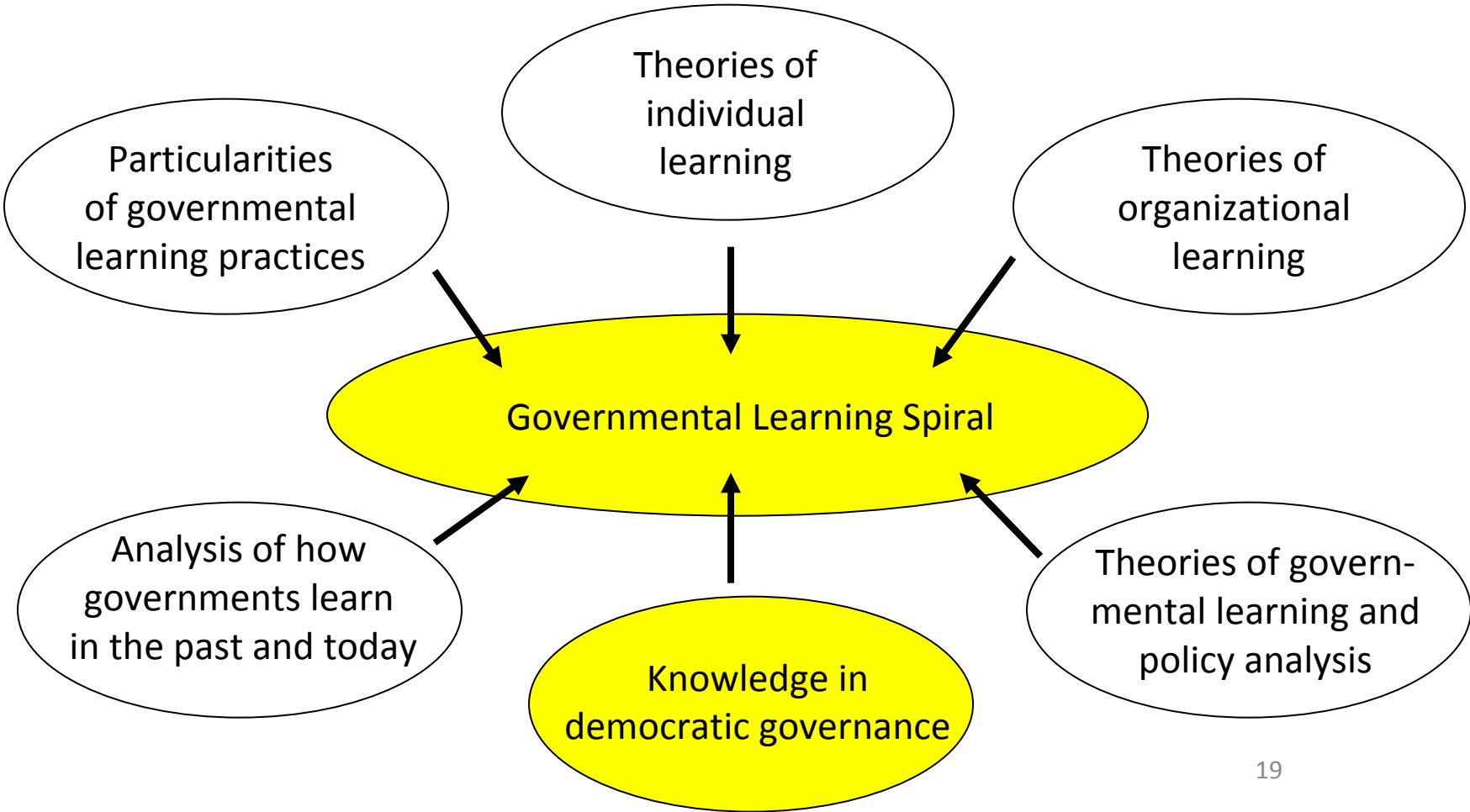

# 4. Theoretical Considerations: Learning Cycle in Democratic Governance

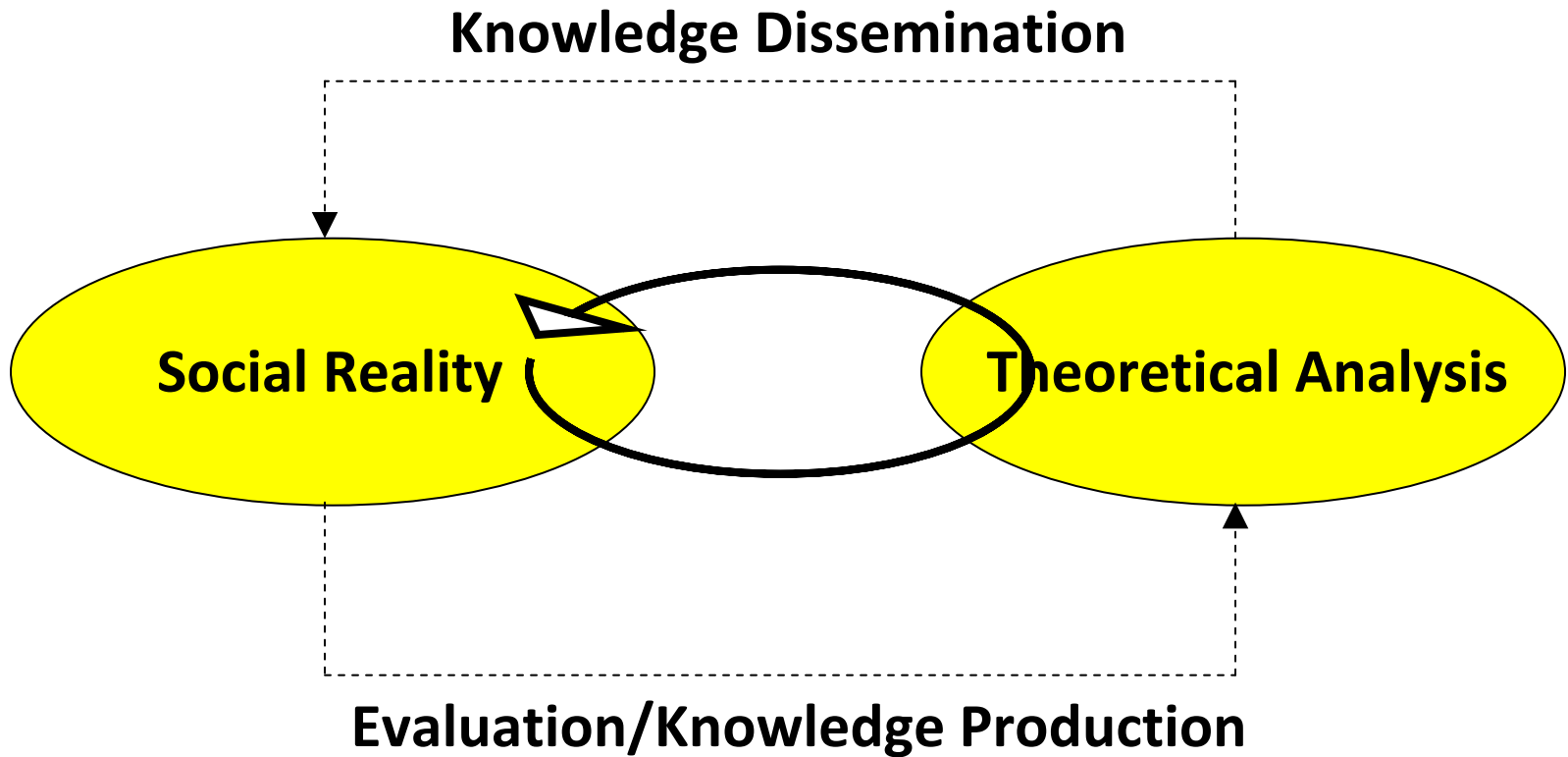

# 4. Theoretical Considerations: Learning Cycle in Democratic Governance

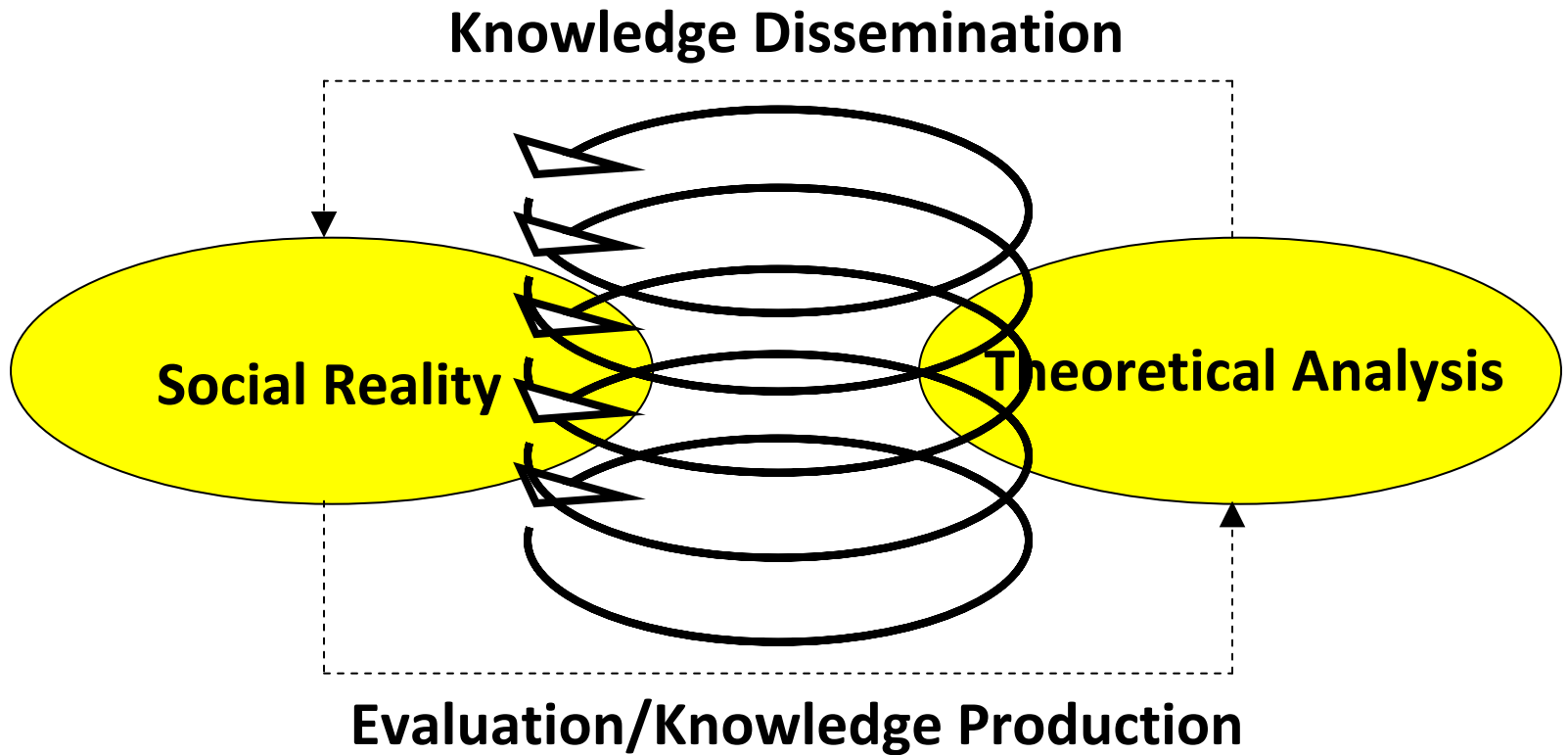

# 5. Template “Governmental Learning Spiral”

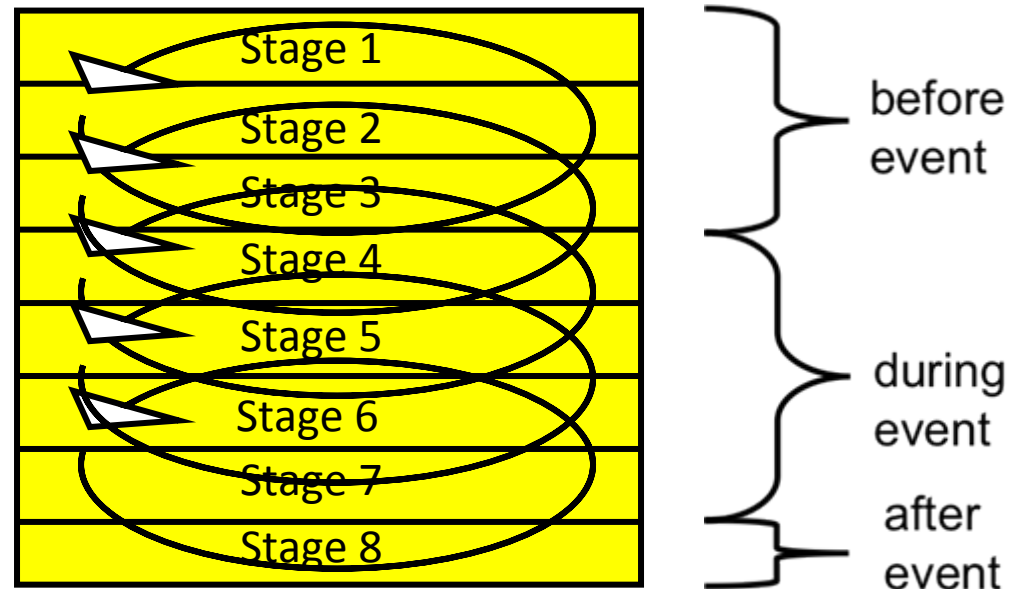

# Stage 1: Conceptualization

- Learning Broker
- Customization knowledge to be learned

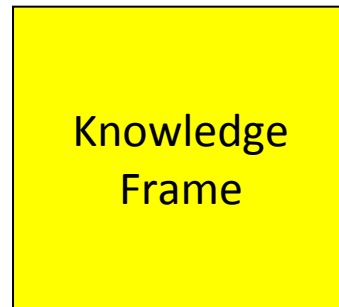

# Stage 2: Triangulation

- Content triangulation
- Stakeholder triangulation

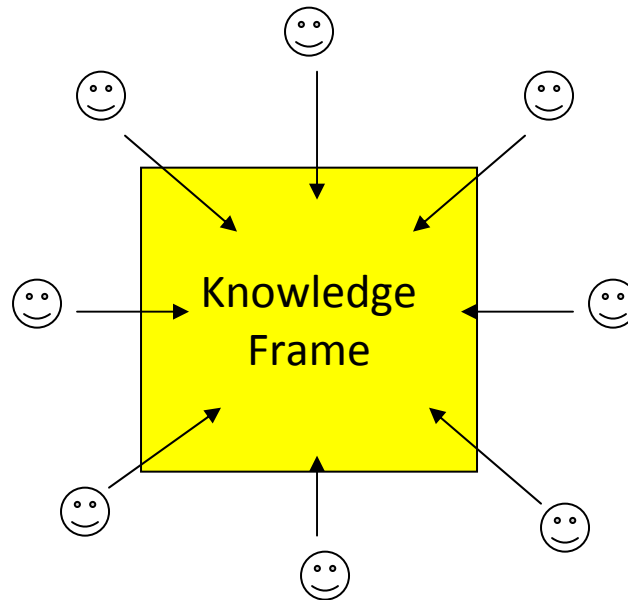





# Stage 3: Accommodation

- Creation of a learning space
- Hierarchy of needs

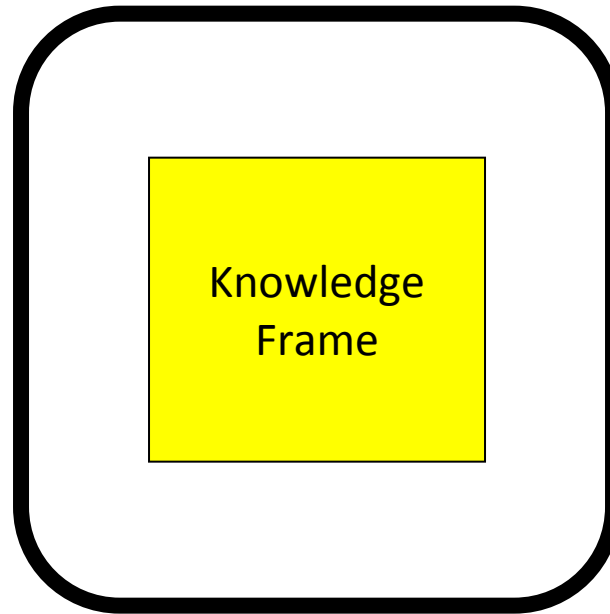



# Stage 4: Internalization

- Space for self-reflection
- Validation of individual reality (deduction)

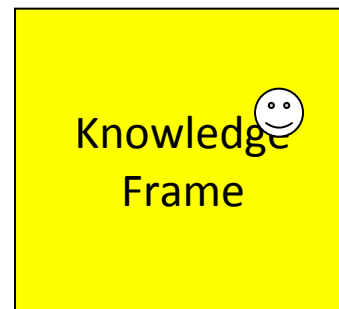



# Stage 5: Externalization

- Space for group reflection
- Validation of collective reality

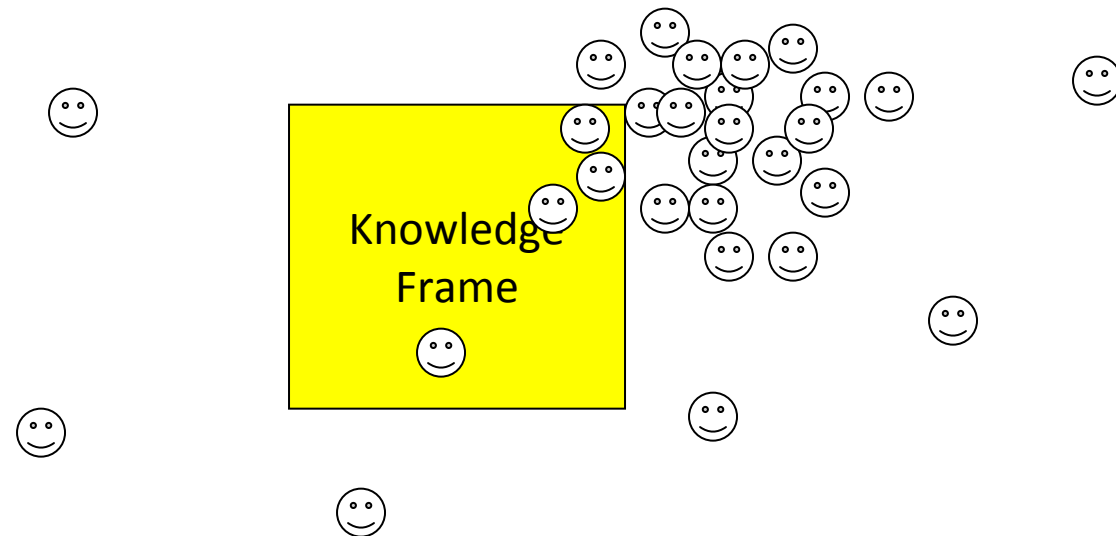

# Stage 6: Reconceptualization

- Overlaps and patterns
- Updating and reframing knowledge (induction)

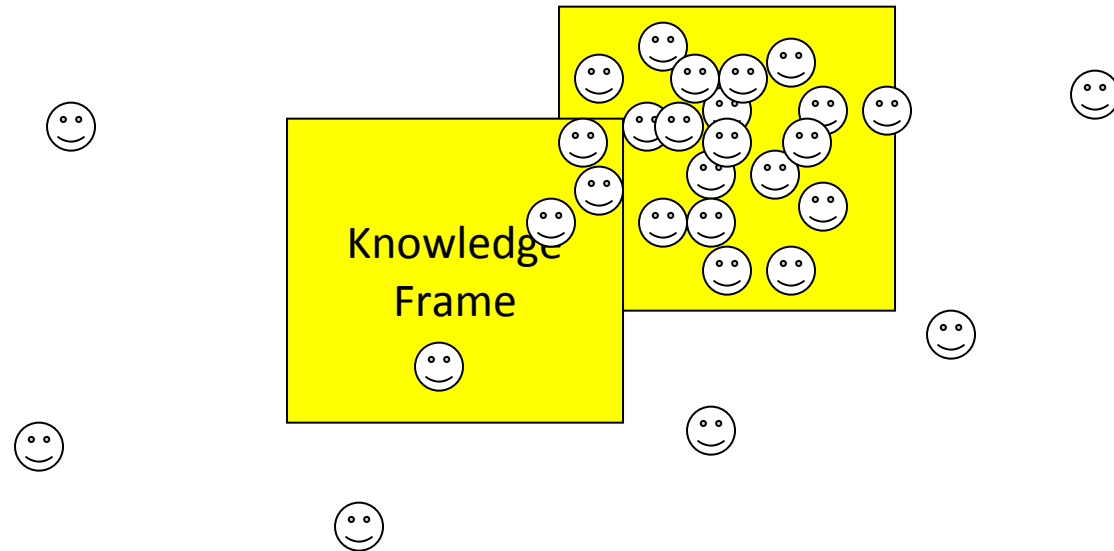

# Stage 7: Transformation

- Deduction reframed knowledge into context
  - Planning implementation (deduction)

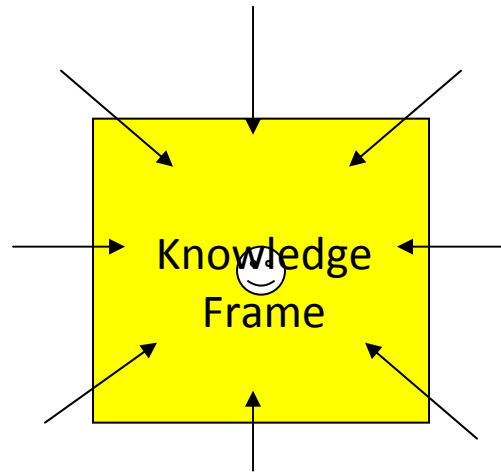

# Stage 8: Configuration

- Configuration of new knowledge (induction)
- Sustainability of learning process

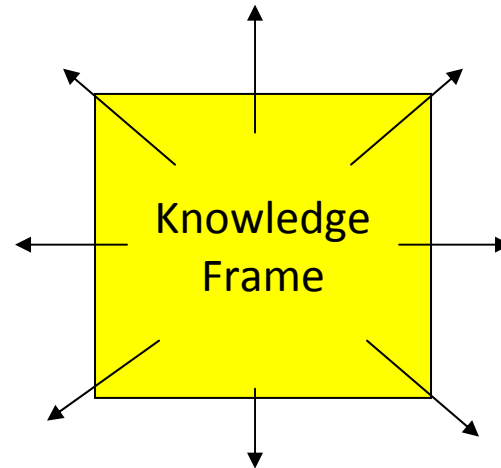



# 5. Template: “Governmental Learning Spiral” System

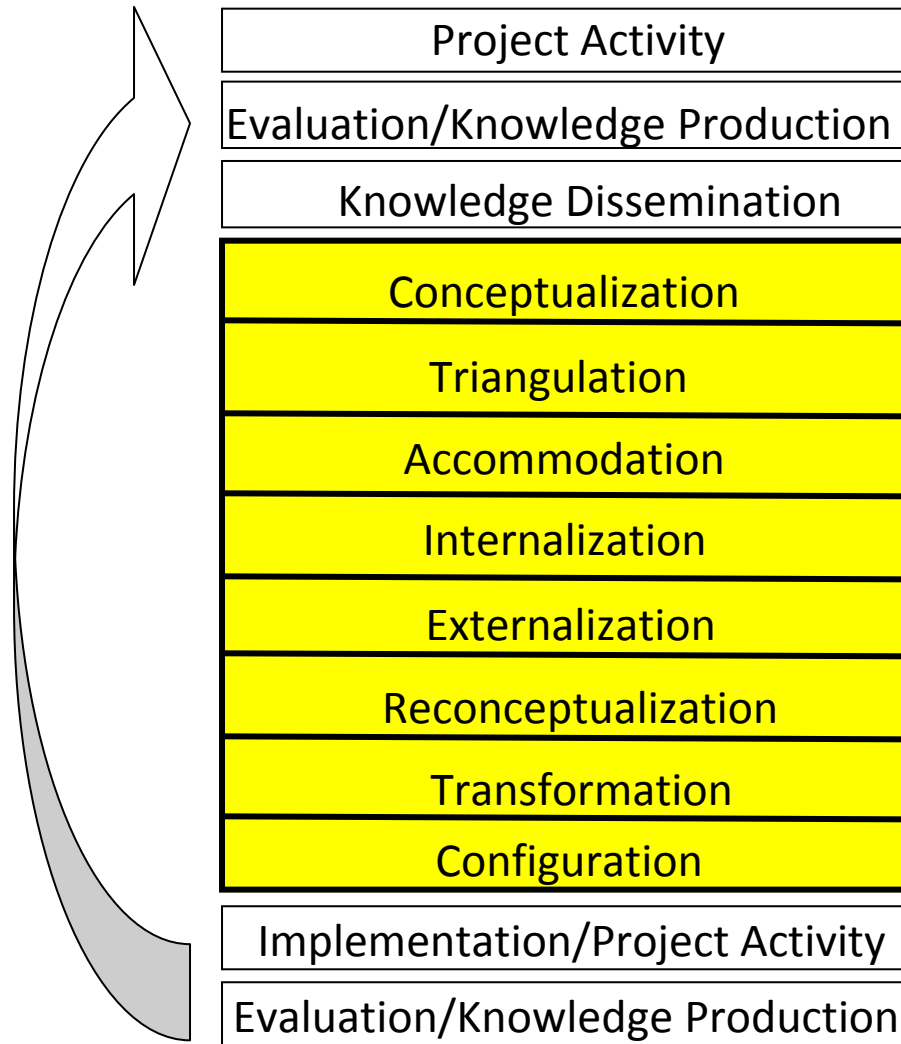

# 6. Practical Application: Eight African States - Public Sector Reform

<b>Conceptualization</b>
Triangulation
Accommodation
Internalization
Externalization
<b>Reconceptualization</b>
Transformation
Configuration

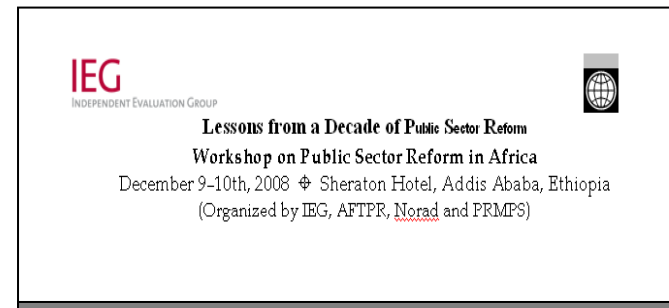



<b>Conceptualization</b>
Triangulation
Accommodation
Internalization
Externalization
<b>Reconceptualization</b>
Transformation
Configuration



- Four evaluation studies on Public Sector Reform summarized in a **concept note**
- Organized in collaboration with AFTPR, PREMPS, WBI, and NORAD
- Sixty participants from eight client countries

Conceptualization
<b>Triangulation</b>
Accommodation
Internalization
Externalization
<b>Reconceptualization</b>
Transformation
Configuration

**Content triangulation:** Authors of the four evaluation reports, international experts on the subject and representatives of the international donor community

**Stakeholder triangulation:** Five participants from each country representing all major spheres on the national and sub-national levels, academics, and representatives of non-governmental organizations



Conceptualization
Triangulation
<b>Accommodation</b>
Internalization
Externalization
<b>Reconceptualization</b>
Transformation
Configuration

- Chatham house rules
- Communication rules
- Recognition of cultural diversities



Conceptualization
Triangulation
Accommodation
<b>Internalization</b>
Externalization
<b>Reconceptualization</b>
Transformation
Configuration

- Presentation of evaluation findings (plenary)
- Reflection of the individual country situations in the light of the presented findings (breakout groups)



Conceptualization
Triangulation
Accommodation
Internalization
<b>Externalization</b>
<b>Reconceptualization</b>
Transformation
Configuration

Participants share their individual reflections  
(plenary session)



Conceptualization
Triangulation
Accommodation
Internalization
Externalization
<b>Reconceptualization</b>
Transformation
Configuration

Participants search for new trends and patterns in Public Sector Reform (open space)



Conceptualization
Triangulation
Accommodation
Internalization
Externalization
Reconceptualization
<b>Transformation</b>
Configuration

Participants develop in country teams **action plans** with concrete recommendations and present them in the plenary



Conceptualization
Triangulation
Accommodation
Internalization
Externalization
<b>Reconceptualization</b>
Transformation
<b>Configuration</b>

- Drafting the workshop findings in a brochure and other multimedia components
- Complement the evaluation reports
- Building virtual network (social medias)

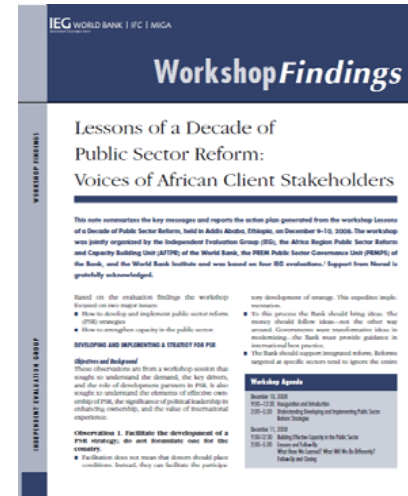



# 7. Conclusions

1. Bridging dissemination and implementation phases
2. Multitude of content and institutional perspectives
3. Participants are knowledge holders and recipients alike
4. Alternate knowledge deduction and induction
5. Knowledge validation and development through iterative process
6. Template application for every new learning event design
7. Content shapes event design
8. Sustainability of governmental learning (networks)
9. Learning outcomes are unpredictable



Schweizerische Eidgenossenschaft  
Confédération suisse  
Confederazione Svizzera  
Confederaziun svizra

Eidgenössisches Justiz- und Polizeidepartement  
**Bundesamt für Justiz**

# Herzlichen Dank für Ihre Aufmerksamkeit!

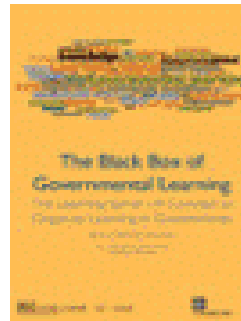

Für weitere Informationen siehe:  
<http://www.worldbank.org/ieg/learningspiral/index.html>